

Centro-Matic[®]

Automated Lubrication Systems



“I install Lincoln Centro-Matic systems with confidence because I know they’re going to prolong the life of my customer’s critical machinery.”

Les Maness, Installation Foreman,
Lincoln Distributor

People, Capabilities and Systems to Save Money and Increase Productivity



We're the largest and most successful company in our field because we continually satisfy our customers with the world's best lubrication and pumping systems. For almost 90 years, companies have relied on our technical and quality leadership, our world-class manufacturing and customer service, and our vast network of distributors and support facilities.

Lincoln develops new products and systems at research and development facilities in the U.S., Germany and India that provide global and regional application solutions.

We have solutions for large processing plants, automotive manufacturing, pulp and paper mills, and food and beverage facilities. Virtually every industrial professional involved in operations and maintenance can benefit from Lincoln systems.

On the road or in the field, Lincoln protects heavy equipment used in mining, construction, agriculture and over-the-road trucking. The world's leading manufacturers offer our systems as standard equipment or factory options.

Lincoln builds precision metal components, state-of-the-art electronic controls, and the industry's top-performing pump systems. Our quality systems in the United States and Germany are ISO 9001 registered.

With five technical support centers on three continents, and a network of systems houses and distributors supported by regional sales and service offices, our customers can always draw on our worldwide resources.

To make sure your investment results in significant savings, Lincoln developed a unique program called BearingSaver®. You not only get a complete audit of your facility, you also receive an analysis of your return on investment.

Industrial Solutions



Worldwide Support



Quality Manufacturing

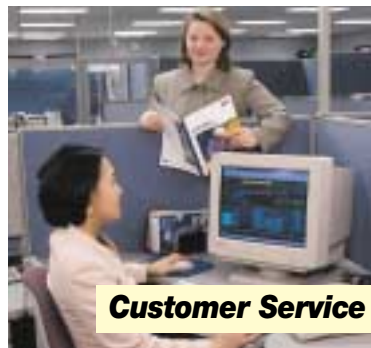

Customer Service



BearingSaver®

Research & Development

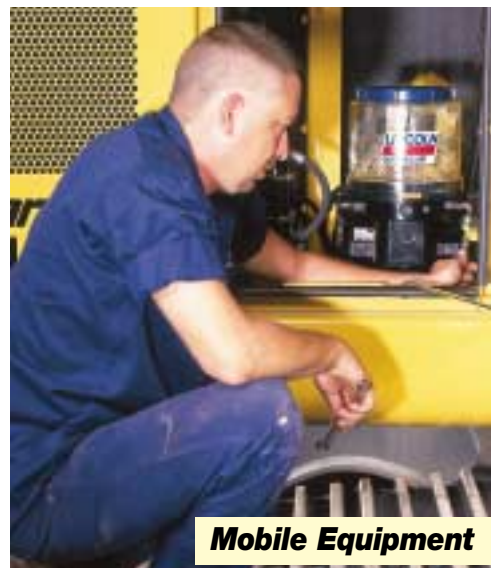
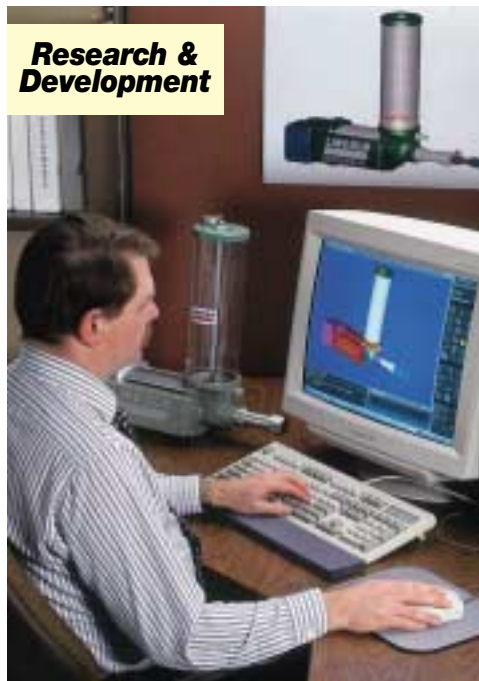

Mobile Equipment

<i>Introduction to Centro-Matic®</i>	2
<i>Grease Injectors</i>	4
<i>Oil Injectors</i>	8
<i>Metric Injectors</i>	12
<i>Injector Accessories</i>	13
<i>Installation Components</i>	15
<i>Manual Grease Pumps</i>	16
<i>Air-Operated Grease Pumps</i>	17
<i>Electric Grease Pumps</i>	21
<i>Manually Operated Oil Pumps</i>	22
<i>Air-Operated Oil Pumps</i>	23
<i>Electric/Hydraulically-Operated Oil Pumps</i>	26
<i>Pump Accessories</i>	27
<i>FlowMaster™ Hydraulic Pump</i>	29
<i>Hydraulic-Powered Grease Pumps</i>	30
<i>Ultrasonic Sensor</i>	31
<i>System Controls</i>	32
<i>Numerical Index</i>	40

Lincoln Centro-Matic® systems and components are made to match your application. Systems can service one machine, different zones on one machine, or even several separate machines. Regardless of the application, the principle of centralized lubrication remains the same: a central pump station automatically delivers lubricant through a single supply line to the injectors. Each injector serves only one lubrication point and may be accurately adjusted to deliver the precise amount of grease or oil required. Centro-Matic systems give you multiple advantages over other designs.

Simplicity

Systems are easy to understand, install and maintain. You realize savings right from the start because one lubricant supply line means lower installation costs.

Powerful Pumping Unit

Centro-Matic systems dispense either grease or oil in measured quantities, unaffected by normal temperature or viscosity changes. For large systems, Lincoln's single-line design and powerful pumps mean injectors can be located long distances from original refinery containers or bulk lubricant tanks.

External Adjustment

Lubricant injectors are externally adjustable without special tools so each bearing can receive the correct amount of lubricant. No under- or over-lubrication at individual points.

Visual Indicators

Each injector incorporates an indicator pin that gives visual confirmation the injector is operating correctly. When necessary, troubleshooting is the simple process of checking indicator pins.

Ease of Service

When injectors finally need service, the job is quick and easy. No need to remove supply line connections or disturb adjacent injectors. Replacement can usually be done between lubrication cycles, so there's almost no lubricant loss or downtime.

Parts and Service

You're never far from a Lincoln authorized distributor. Qualified distributors offer design engineering, startup help, and training for your personnel in the use and maintenance of Centro-Matic systems. They'll back you up with parts and service for years after the sale.

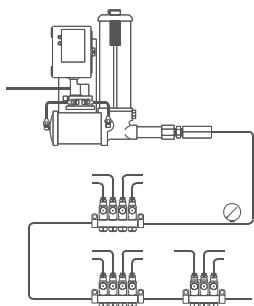

Air-Operated

Actuated automatically by compressed air at various pre-determined intervals. An air-operated pump delivers lubricant to the injectors. When all injectors have cycled, the pump shuts off automatically and vents lubricant pressure. Available with automatic, manual or mechanical controls.

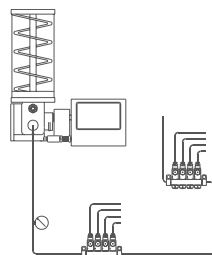

Electric

Used where compressed air is not available, or electrical operation is preferred. Totally enclosed motor supplies the power requirements of the pumping mechanism. Time control is adjustable to provide predetermined frequency of lubrication.

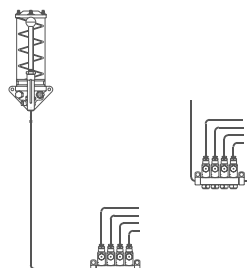

Manual

Designed for smaller, individual machines, manual systems provide a low-cost, efficient method of distributing lubricant to the injectors. Cycling a complete bank of injectors takes only a few seconds. In manually-operated systems, the lubricant pump is hand-operated and the machine operator performs the lubrication intervals.

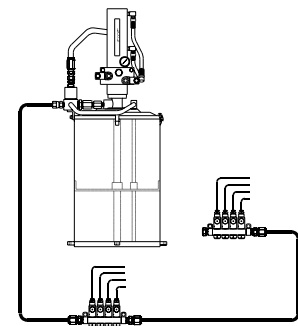

Hydraulic

A complete hydraulically-powered pumping unit for centralized lubrication of individual machines. Usually installed on machinery such as coal mining and earth moving equipment which utilize a hydraulic pressure system. The frequency of the lubrication cycle can be set manually or by mechanical or automatic controls.

Basic Operating Principles of Centro-Matic® Injectors

Each Lincoln Centro-Matic injector can be manually adjusted to discharge the precise amount of lubricant each bearing needs. Injectors are mounted singly at each bearing, or grouped in a manifold with feedlines supplying lubricant to the bearings. In each case, injectors are supplied with lubricant under pump pressure through a single supply line. Two injector types are available: one with a top adjustment and one with a side adjustment. Both types can be used in the same circuit; their selection is made on the basis of bearing lubricant requirements.

SL-1, -11, -41, -44

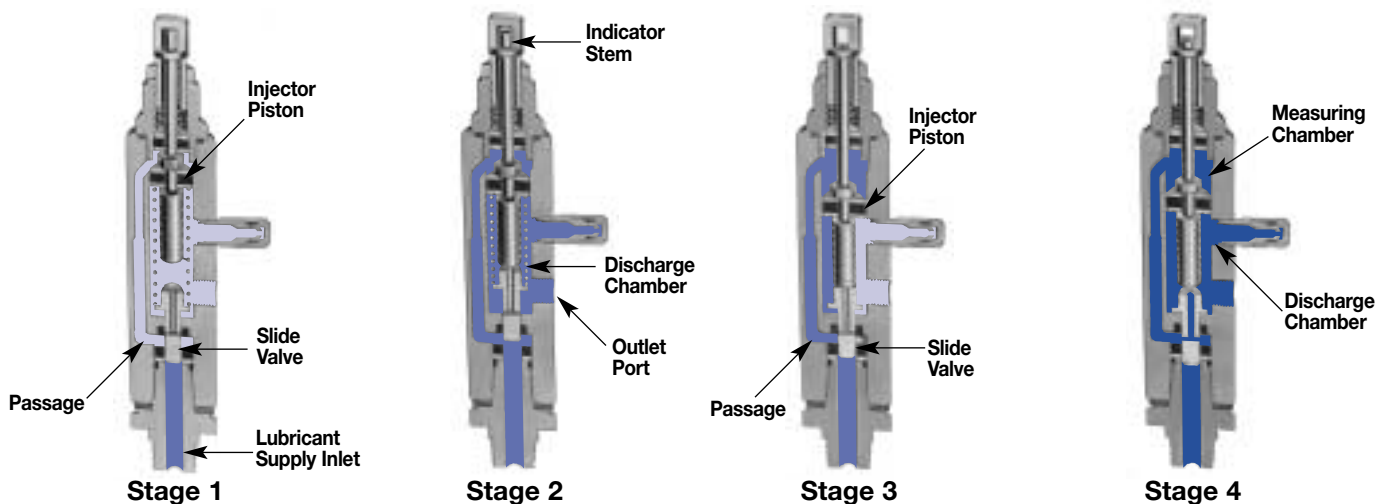

Stage 1—The injector piston is in its normal, or rest position. The discharge chamber is filled with lubricant from the previous cycle. Under the pressure of incoming lubricant, the slide valve is about to open the passage leading to the piston.

Stage 2—When the slide valve uncovers the passage, lubricant is admitted to the top of the piston, forcing the piston down. The piston forces lubricant from the discharge chamber through the outlet port to the bearing.

Stage 3—As the piston completes its stroke, it pushes the slide valve past the passage, cutting off further admission of lubricant to the passage. Piston and slide valve remain in this position until lubricant pressure in the supply line is vented (relieved) at the pump.

Stage 4—After pressure is relieved, the compressed spring moves the slide valve to the closed position. This opens the port from the measuring chamber and permits the lubricant to be transferred from the top of the piston to the discharge chamber.

SL-32, -33, -42, -43

Stage 1—Incoming lubricant, under pressure from the supply line, moves the injector piston forward. The piston forces a pre-charge of lubricant from the discharge chamber through the outlet check valve to the feed line.

Stage 2—When the system is vented (pressure relieved), the piston returns to the rest position, transferring lubricant from the measuring chamber to the discharge chamber.

Applications—When it comes to eliminating costly, manual point-by-point lubrication, Centro-Matic systems have proven to be the right solution for many industries and applications. Examples include:

- Paper Converting
- Plastic Processing
- Wood Processing
- Printing
- Packaging
- Textile
- Food & Beverage
- Metalworking
- Material Handling Equipment

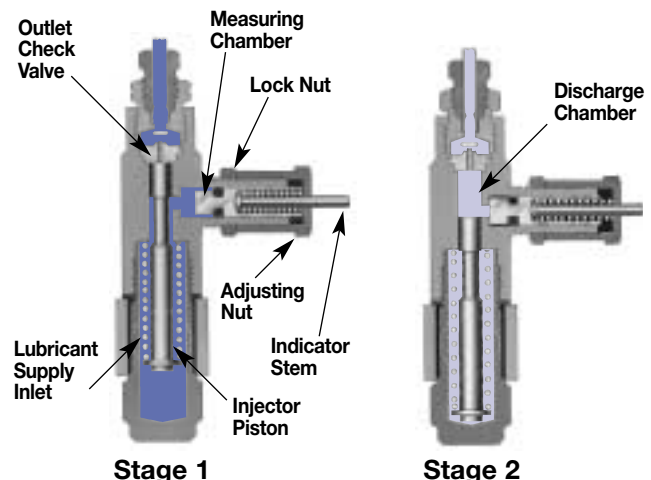

Series SL-33

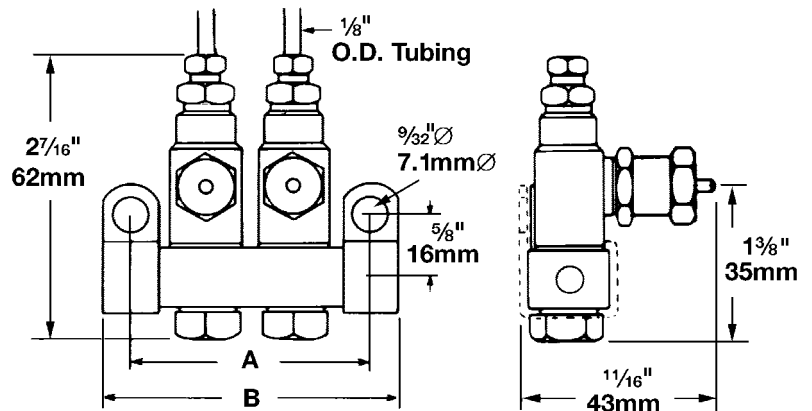

- For single-line high pressure central lubrication system.
- For dispensing petroleum-based lubricants with a viscosity up to NLGI No. 2 (refer to Design Guide).
- Output is externally adjustable.
- Indicator stem permits visual check of injector operation.
- May be combined in a circuit of Injectors SL-32, SL-1 and/or SL-11.
- Individual injectors can be easily removed for inspection or replacement.
- Available in stainless steel SAE 304, for application where environmental conditions are hazardous to carbon steel or in industries preferring stainless steel.

Specifications:

Series	Output		Operating Pressure			
	Min	Max	Min	Max	Typical	Vent
SL-33	.001 cu. in. .016 cc	.003 cu. in. .049 cc	1200 psig 83 bar	3500 psig 241 bar	1500 psig 103 bar	200 psig 14 bar

Model		Number of Outlets	Connections		Dimensions			
Carbon Steel	Stainless Steel (304)		Manifold Inlet	Injector Outlet	A		B	
				in.	mm	in.	mm	
83309-1	83715-1	1	1/8" NPTF (F)	1/8" O.D. Tube	1 1/8	29	1 1/8	41
83309-2	83715-2	2			1 1/2	48	2 3/8	60
83309-3	83715-3	3			2 1/8	67	3 1/8	79
83309-4	83715-4	4			3 1/8	86	3 7/8	98
83309-5	—	5			4 1/8	105	4 5/8	117
83309-6	83715-6	6			4 7/8	124	5 1/8	137
—	83715-7	7			5 1/8	143	6 1/8	156
83900	83900-9	1	1/8" NPTF (M)	Single Injector/No Manifold				
83314	83314-9	—	—	Single Replacement Injector				

Notes:

1. Injectors, except replacement injectors for manifold, include compression nut and ferrule for tubing — 1/8" O.D. as standard. Other outlet connectors for feed line optional.
2. Injectors with manifolds include two mounting clips and screws.
3. Injectors have Nitrile packings (200°F max. / 93°C). Check packing compatibility with synthetic lubricants.
4. Output with indicator cap hand tightened is .001 cu. in. Maximum output is achieved with two turns at .001 cu. in./turn.

Series SL-32

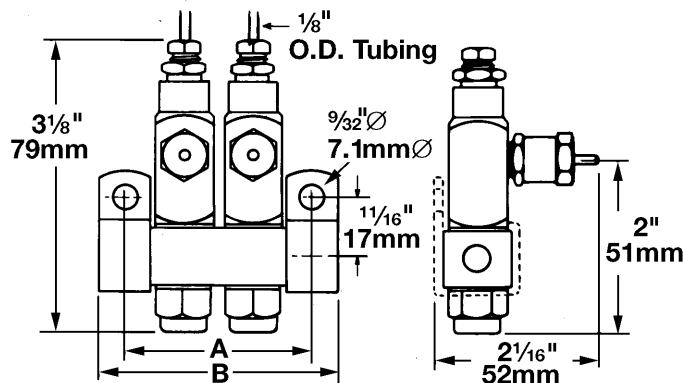
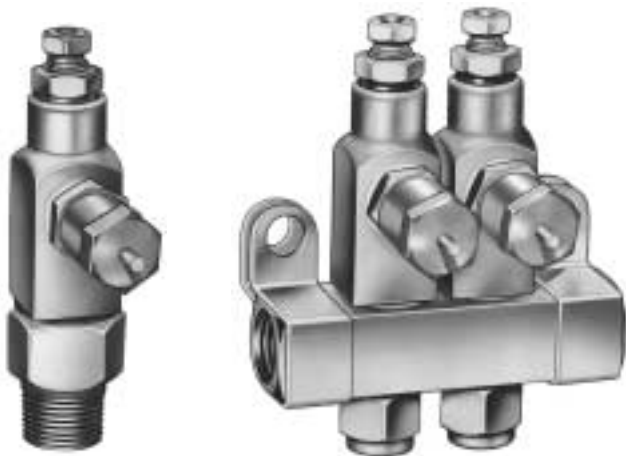

- For single-line high pressure central lubrication system.
- For dispensing petroleum-based lubricants with a viscosity up to NLGI No.2 (refer to Design Guide).
- Output is externally adjustable.
- Indicator stem permits visual check of injector operation.
- May be combined in a circuit of injectors SL-33, SL-1 and/or SL-11.
- Individual injectors can be easily removed for inspection or replacement.
- Available in stainless steel SAE 304, for application where environmental conditions are hazardous to carbon steel or in industries preferring stainless steel.

Specifications:

Series	Output		Operating Pressure			
	Min	Max	Min	Max	Typical	Vent
SL-32	.001 cu. in. .016 cc	.008 cu. in. .131 cc	1200 psig 83 bar	3500 psig 241 bar	1500 psig 103 bar	200 psig 14 bar

Model		Number of Outlets	Connections		Dimensions			
Carbon Steel	Stainless Steel (304)		Manifold Inlet	Injector Outlet	A		B	
				in.	mm	in.	mm	
83336-1	83724-1	1	1/4" NPTF (F)	1/8" O.D. Tube	1 1/4	32	1 1/4	44
83336-2	83724-2	2			2	51	2 1/2	63
83336-3	83724-3	3			2 3/4	70	3 1/4	83
83336-4	83724-4	4			3 1/2	89	4	102
83338	—	1	1/4" NPTF (M)	Single Injector/No Manifold				
83337	83337-9	—	—	Replacement for manifold injectors				

Notes:

1. Injectors, except replacement injectors for manifold, include compression nut and ferrule for tubing — 1/8" O.D. as standard. Other outlet connectors for feed line optional.
2. Injectors with manifolds include two mounting clips and screws.
3. Injectors have Nitrile packings (200°F max. / 93°C). Check packing compatibility with synthetic lubricants.
4. Output with indicator cap hand tightened is .001 cu. in. Maximum output is achieved with five turns at .0014 cu. in./turn.

Series SL-1

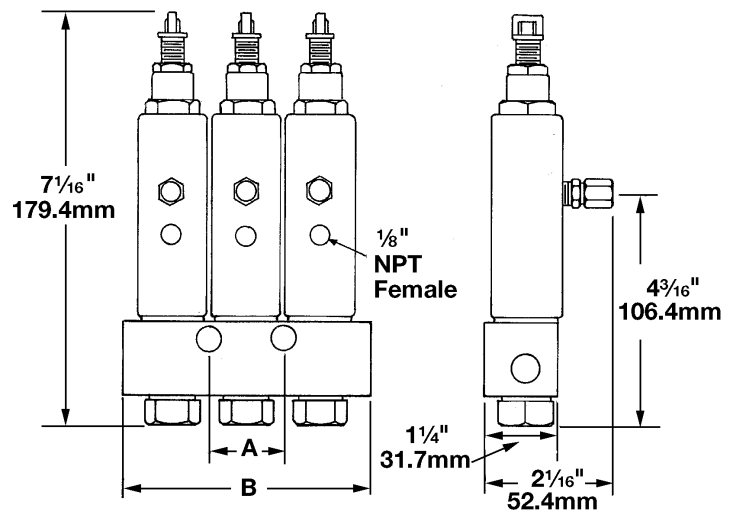

- For single-line high pressure central lubrication system.
- For dispensing lubricants compatible up to NLGI No. 2 (refer to Design Guide).
- Output is externally adjustable.
- Indicator stem permits visual check of injector operation.
- May be combined in a circuit of injectors SL-32, SL-33 and/or SL-11.
- Individual injectors can be easily removed for inspection or replacement.
- Available in stainless steel SAE 316, for application where environmental conditions are hazardous to carbon steel or in industries preferring stainless steel.

Specifications:

Series	Output		Operating Pressure				Connections	
	Min	Max	Min	Max	Typical	Vent	Manifold Inlet	Injector Outlet
SL-1	.008 cu. in. .131 cc	.080 cu. in. 1.31 cc	1850 psig 127 bar	3500 psig 241 bar	2500 psig 172 bar	600 psig 41 bar	3/8" NPTF (F)	1/8" NPTF (F)

Carbon Steel	Model		Special Applications**	Number of Outlets	Dimensions			
	Stainless Steel (316)				A		B	
					in	mm	in	mm
81770-1	239351*	One Injector Manifold	85451-1	1	Single Mounting		2 1/2	63
81770-2	239352*	Two Injector Manifold	85451-2	2	Hole		3	76
81770-3	239353*	Three Injector Manifold	85451-3	3	1 1/4	32	4 1/4	108
81770-4	239354*	Four Injector Manifold	85451-4	4	2 1/2	63	5 1/2	140
81770-5	239355*	Five Injector Manifold	85451-5	5	3 3/4	95	6 3/4	171
81770-6		—	85451-6	6	5	23	8"	203
81713	246965*	Six Injector Manifold	249204	Single injector/No Manifold, [3/8" NPTF (M) inlet]				
81713A	84776*	Injector	85451	Replacement for manifolded injectors				

* For complete assembly, you must order stainless steel manifold and corresponding quantity of Model #84776 Injectors separately.

** For use with aggressive lubricants that attack Viton seals at high temperatures.

Notes:

1. Injector manifolds have 1 3/8" (10.3 mm) dia. mounting holes for 3/8" bolt.
2. Injectors have Viton packings. Check compatibility with synthetic lubricants.
3. Injector rated for 350°F (176°C) max. ambient temperature, depending on lubricant used.
4. Injectors include fitting for filling feedlines via alternate outlet port.
5. Output with adjustment screw hand tightened is .009 cu. in. Maximum output is achieved with eight turns at .009 cu. in./turn.

Series SL-11

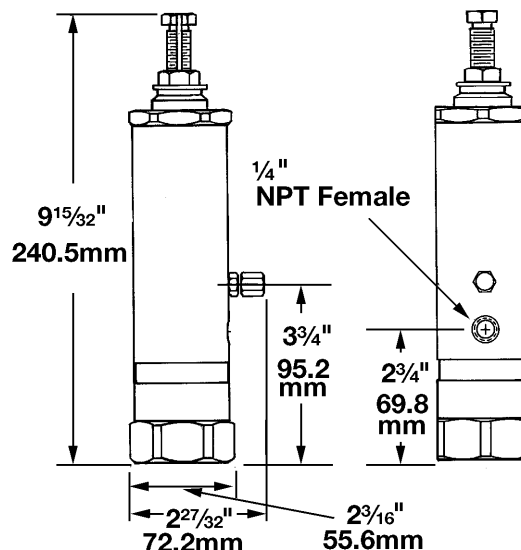

- For single-line high pressure central lubrication system.
- For dispensing lubricants compatible with Viton and Hytrel packings and viscosity up to NLGI No. 2 (refer to Design Guide).
- Output is externally adjustable.
- Indicator stem permits visual check of injector operation.
- May be combined in a circuit of injectors SL-32, SL-33 and/or SL-1.
- Available only as single unit with 1/2" NPTF Female inlet.

Specifications:

Series	Output		Operating Pressure			
	Min	Max	Min	Max	Typical	Vent
SL-11	.050 cu. in. .82 cc	.500 cu. in. 8.2 cc	1000 psig 69 bar	3500 psig 241 bar	2500 psig 172 bar	800 psig 55 bar

Model Carbon Steel	Number of Outlets	Connections	
		Inlet	Outlet
85497	1	1/2" NPTF (F)	1/4" NPTF (F)

Notes:

1. Injectors have Viton and Hytrel packings. Check packing compatibility with synthetic lubricants.
2. Injector rated for 200°F (93°C) max. ambient temperature.
3. Injectors supplied with fitting for filling feed line via alternate outlet port.
4. Output with adjustment screw hand tightened is .05 cu. in. Maximum output is achieved with 11 1/2 turns at .040 cu. in./turn.

Series SL-42

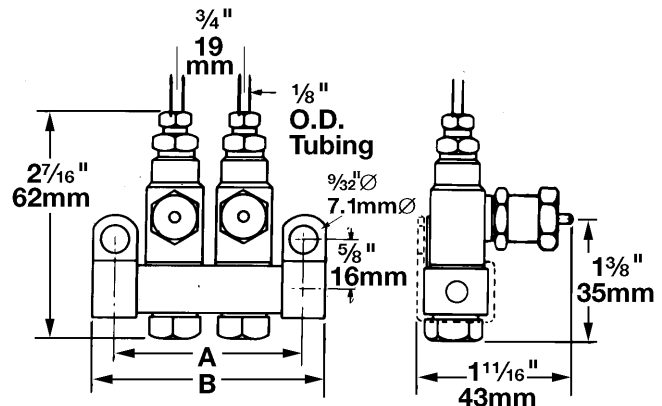

- For single-line central lubrication system.
- For dispensing fluid or semi-fluid lubricants.
- Output is externally adjustable.
- Indicator stem permits visual check of injector operation.
- May be combined in a circuit of injectors SL-43, SL-41 and/or SL-44.
- Individual injectors can be easily removed for inspection or replacement.
- Carbon steel injectors with Nitrile or Viton packings.
- Injectors with Viton packings are used for heat resistant applications or when lubricant to be dispensed requires Viton packings for compatibility (indicated by black adjustment caps).

Specifications:

Series	Output		Operating Pressure			
	Min	Max	Min	Max	Typical	Vent
SL-42	.001 cu. in. .016 cc	.003 cu. in. .049 cc	750 psig 52 bar	1000 psig 69 bar	850 psig 59 bar	150 psig 10 bar

Model		Number of Outlets	Connections		Dimensions			
Carbon Steel			Manifold/ Injector Inlet	Injector Outlet	A		B	
Standard	Heat Resistant				in	mm	in	mm
83311-1	84428-1	1	1/8" NPTF (F)	1/8" O.D. Tube Connection	1 1/8	29	1 1/8	41
83311-2	84428-2	2			1 3/8	48	2 3/8	60
83311-3	84428-3	3			2 5/8	67	3 3/8	79
83311-4	84428-4	4			3 3/8	86	3 7/8	98
83311-5	84428-5	5			4 1/8	105	4 5/8	117
83311-6	84428-6	6			4 7/8	124	5 3/8	137
83311-10	84428-10	10			7 7/8	200	8 3/8	213
83311-15	84428-15	15			11 1/8	295	12 1/8	308
83535	—	1			1/8" NPTF (M)	Single Injector/No Manifold		
83313	84048	—	—	Replacement for manifolded injectors				

Notes:

1. Injectors, except replacement injectors for manifold, include compression nut and ferrule for tubing — 1/8" O.D. as standard. Other outlet connectors for feed line optional.
2. Injectors with manifolds include two mounting clips and screws.
3. Standard injectors have Nitrile packings (200°F/93°C max.); Heat Resistant injectors have Viton packings (350°F/176°C max., depending on lubricant used). Check packing compatibility with synthetic lubricants.
4. Output with indicator cap hand tightened is .001 cu. in. Maximum output is achieved with two turns at .001 cu. in./turn.

Series SL-43

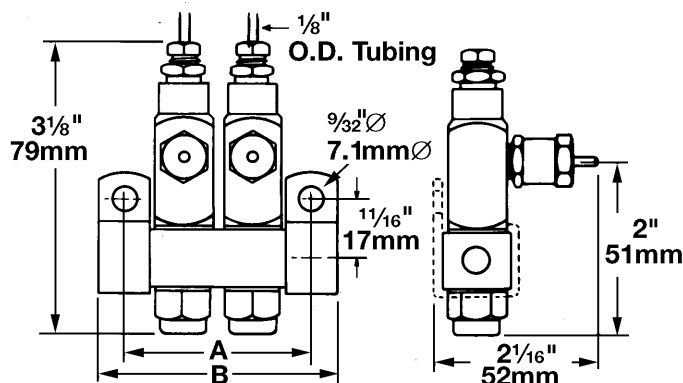

- For single-line central lubrication system.
- For dispensing fluids or semi-fluid lubricants.
- Output is externally adjustable.
- Indicator stem permits visual check of injector operation.
- May be combined in a circuit of injectors SL-42, SL-41 and/or SL-44.
- Individual injectors can be easily removed for inspection or replacement.
- Carbon steel injectors with Nitrile or Viton packings.
- Injectors with Viton packings are used for heat resistant applications or when lubricant to be dispensed requires Viton packings for compatibility (indicated by black adjustment caps).

Specifications:

Series	Output		Operating Pressure			
	Min	Max	Min	Max	Typical	Vent
SL-43	.001 cu. in. .016 cc	.008 cu. in. .131 cc	750 psig 52 bar	1000 psig 69 bar	850 psig 59 bar	150 psig 10 bar

Model		Number of Outlets	Connections		Dimensions			
Carbon Steel			Manifold/ Injector Inlet	Injector Outlet	A		B	
Standard	Heat Resistant	in			mm	in	mm	
83661-1	84429-1	1	1/4" NPTF (F)	1/8" O.D. Tube Connection	1 1/4	32	1 3/4	44
83661-2	84429-2	2			2	51	2 1/2	63
83661-3	84429-3	3			2 3/4	70	3 1/4	83
83661-4	84429-4	4			3 1/2	89	4	102
83660	84110	—	—	Replacement for manifolded injectors				

Notes:

1. Injectors, except replacement injectors for manifold, include compression nut and ferrule for tubing — 1/8" O.D. as standard. Other outlet connectors for feed line optional.
2. Injectors with manifolds include two mounting clips and screws.
3. Standard injectors have Nitrile packings (200°F/93°C max.)
4. Heat Resistant injectors have Viton packings (350°F/176°C max. depending on lubricant used) and Black Adjusting Cap.
5. Check packing compatibility with synthetic lubricants.
6. Output with indicator cap hand tightened is .001 cu. in. Maximum output is achieved with five turns at .0014 cu. in./turn.

Series SL-41

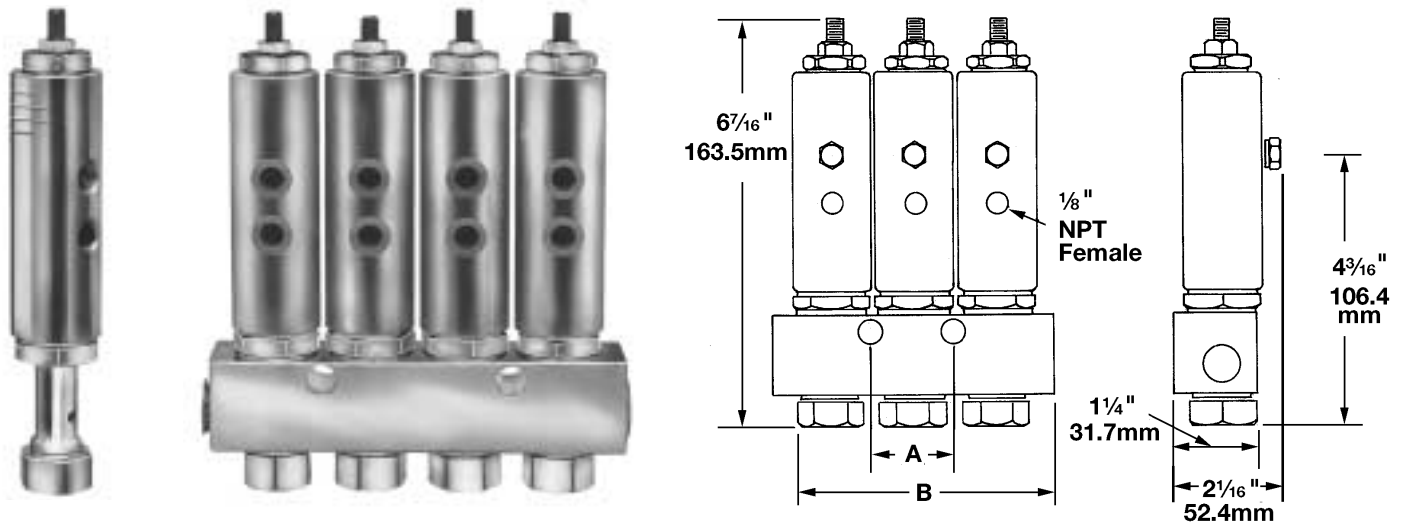

- SL-41 series injectors are designed for use in high temperature applications up to 350°F (176°C), depending on lubricant.
- Available installed only in manifolds with 1/8" NPT female inlet.
- Injectors feature a tamper-resistant adjustment screw which does not incorporate a visual indicator.
- May be combined in a circuit of injectors SL-42, SL-43 and SL-44.

Specifications:

Series	Output		Operating Pressure			
	Min	Max	Min	Max	Typical	Vent
SL-41	.008 cu. in. .131 cc	.080 cu. in. 1.31 cc	750 psig 52 bar	1000 psig 69 bar	850 psig 59 bar	150 psig 10 bar

Model	Number of Outlets	Connections		Dimensions			
		Manifold Inlet	Injector Outlet	A		B	
				in	mm	in	mm
82294-1	1	3/8" NPTF (F)	1/8" NPTF (F)	Single Hole		2 1/2	63
82294-2	2			Mounting		3	76
82294-3	3			1 1/4	32	4 1/4	108
82294-4	4			2 1/2	63	5 1/2	140
82294-5	5			3 3/4	95	6 3/4	171
82295	—	—	—	Replacement for manifolded injector			

Notes:

1. Injector manifolds have 1 3/32" (10.3 mm) mounting holes for 3/8" bolt.
2. Output with adjustment screw hand tightened is .008 cu. in. Maximum output is achieved with 12 turns at .006 cu. in./turn.

Series SL-44

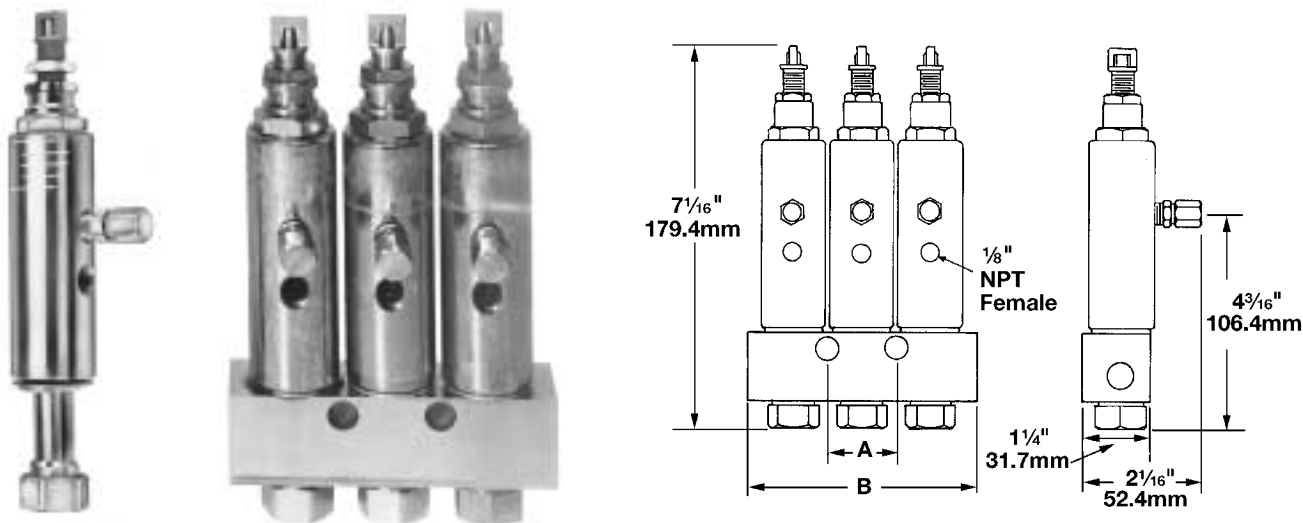

- For single-line central lubrication system.
- For dispensing fluid or semi-fluid lubricants.
- Output is externally adjustable.
- Indicator stem permits visual check of injector operation.
- May be combined in a circuit of injectors SL-43, SL-41 and/or SL-42.
- Individual injectors can be easily removed for inspection or replacement.
- Carbon steel injectors with Viton packings.

Specifications:

Series	Output		Operating Pressure				Connections	
	Min	Max	Min	Max	Typical	Vent	Manifold Inlet	Injector Outlet
SL-44	.008 cu. in. .131 cc	.080 cu. in. 1.31 cc	750 psig 52 bar	1000 psig 69 bar	850 psig 59 bar	150 psig 10 bar	3/8" NPTF (F)	1/8" NPTF (F)

Model	Number of Outlets	Dimensions			
		A		B	
		in	mm	in	mm
83749-1	1	Single Mounting Hole		2 1/2	63
83749-2	2	Single Mounting Hole		3	76
83749-3	3	1 1/4	32	4 1/4	108
83749-4	4	2 1/2	63	5 1/2	140
83749-5	5	3 3/4	95	6 3/4	171
83748	1	Replacement for manifolded injectors			

Notes:

1. Injector manifolds have 13/32" mounting holes for 3/8" bolt.
2. Injectors have Viton packings. Check packing compatibility with synthetic lubricants.
3. Injectors rated at 350°F (176°C) maximum ambient temperature, depending on lubricant used.
4. Output with adjustment screw hand tightened is .009 cu. in. Maximum output is achieved with eight turns at .009 cu. in./turn.

Series SL-32, 33 and 42 Metric

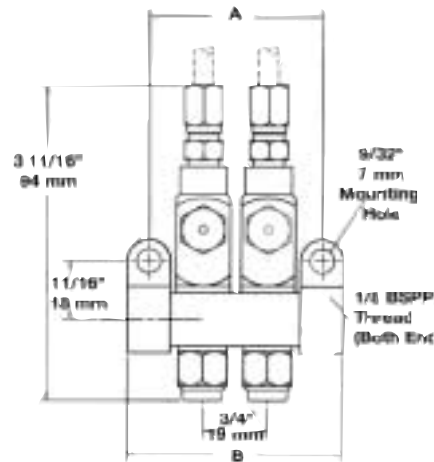

SL-32 Series

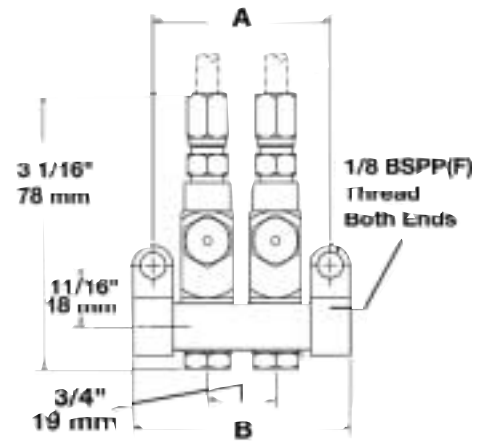

SL-33, 42 Series

With the same proven design as our U.S. standard injectors, the new metric versions of our popular small grease and oil injectors feature metric ports. Any surface that needs a wrench is metric. It's more convenient for customers in most of the world, and easier to maintain because there's no need for a second set of wrenches or adapters.

- Offered for international customers.
- Metric ports connect with metric lines without adapters.
- No need for a second set of tools.
- Proven design used in the United States.
- Models for both grease and oil.

Specifications:

Model			Outlets	Connections		Dimension A		Dimension B	
Oil SL-42	Grease SL-33	Grease SL-32		Inlet	Outlet	in.	mm.	in.	mm.
85351-1	85352-1		1	1/8" BSPP(F)	6 mm O.D. Tube Connection	1 1/8	29	1 1/8	41
85351-2	85352-2		2			1 1/4	48	1 3/8	60
85351-3	85352-3		3			1 3/8	67	1 7/8	79
85351-4	85352-4		4			1 7/8	86	2 1/8	98
85351-5	85352-5		5			2 1/8	105	2 3/8	118
85351-6	85352-6		6			2 3/8	124	3 1/8	137
		85353-1	1			3 1/8	32	1 3/4	44
		85353-2	2			4	51	2 1/2	64
		85353-3	3			4 1/8	70	3 1/4	83
		85353-4	4			4 3/8	89	4	102



Injector Connector Tube

Permits application of combined discharge of two or more Series SL-1, SL-41 or SL-44 injectors through one feed line. Used where bearing size is such that multiple injector output is required. Fittings 1/8" NPT male each end. Carbon steel construction.

Model	For Injector Series	Connections
81646	SL1, SL41, SL44	1/8" NPTF Male



Injector Outlet Adapter

Converts individual injector lubricant outlet when standard 1/8" O.D. tube is not desired. All adapters are carbon steel unless otherwise noted.

Model	For Injector Series	Outlet Connections
14988	SL32, SL33, SL42, SL43	1/8" NPTF Female
84200		1/4" O.D. Tube
14991		1/8" NPTF Male
249279*		4 mm Tube
249280*		6 mm Tube
249281		4 mm Tube
249282		6 mm Tube

* Stainless steel



Manual Grease Fitting Adapter

Allows manual lubrication of the machine between normal system cycles. Carbon steel with Nitrile seals.

Model	For Injector Series	Outlet Connections
84195	SL32, SL33, SL42, SL43	1/8" O.D. Tube
84203		1/4" O.D. Tube



Injector Locking Cap

Carbon steel locking caps set injectors to fixed output.

Model	For Injector Series	Fixed Volume Output
102781	SL32, SL43	.002 in ³ / .033 cc
	SL33, SL42	.003 in ³ / .049 cc



Injector Cover Caps

Injector cover caps are designed to protect the injector from dirt, harmful liquids and fumes.

Model	Fits Injector Series	Covers	Material	Length		Diameter	
				in	mm	in	mm
83272	SL1, SL44	Indicator Stem	Vinyl	1.5	38.1	.69(ID)	17.5
83730	SL11			2.0	50.8	1.125(ID)	28.6
68483	SL32, SL33, SL42, SL43	Measuring Chamber		1.25	31.2	.5(ID)	12.7
84825			Hard Lucite	.61	15.5	.67(OD)	17.0
90537	SL1, SL41, SL44	Injector Body	Aluminum	3.25	82.6	1.19(ID)	30.2

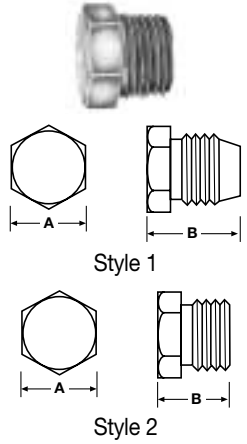

Closure Plugs for Injectors and Manifolds

For use in plugging lubricant outlets of injectors and manifolds.

Model	Material	Thread Size (in)	A in. / mm	B in. / mm	Style
12698*	Carbon Steel	5/16 -24	5/16 / 7.9	1/2 / 12.7	1
12698-9*	Stainless Steel				
12511	Carbon Steel	1/8 PTF	7/16 / 11.1	7/16 / 11.1	2
12511-9	Stainless Steel				
67044	Carbon Steel	3/8 NPT	7/16 / 11.1	13/16 / 20.6	2
67007		1/4 NPT	3/16 / 4.8	5/8 / 15.9	2
67007-9	Stainless Steel				

* For plugging outlet of series SL-32, SL-33, SL-42, SL-43 injectors.

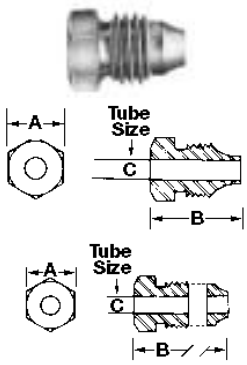

Compression Nuts

Model	Style	Material	Thread Size (in)	A in. / mm	B in. / mm	C in. / mm
66260	One Piece	Brass	5/16-24	5/16 / 7.9	1/2 / 12.7	1/8 / 3.2
66260-9		Stainless Steel				
83924	Two Piece	Brass				
83924-9		Stainless Steel				
66713	One Piece	Brass	7/16-24	7/16 / 11.1	5/8 / 15.9	1/4 / 6.3

Injector-Operated Air Valve



Model	For Injector Series	Air Inlet	Air Outlet
82272	SL-1, SL-44	1/8" NPTF(F)	1/8" NPTF(F)

Air Lubricant Spray Devices



Model	Use With Series	Air Inlet (in)	Lubricant Inlet (in)	Spray Outlet	Air Consumption		
68421	SL1, SL44	1/4 NPTF Female	1/4 NPTF Female	Fixed Nozzle	3.5 CFM @40 PSI	4.1 CFM @60 PSI	5.2 CFM @80 PSI
69456				Swivel Nozzle	99 l/min @2.8 bar	116 l/min @4.1 bar	147 l/min @5.5 bar
68587*				Bulkhead Mount			
84204	SL32, SL33, SL 42, SL43	1/8 NPTF Female	7/16 -24 Male	Fixed Nozzle	Throttle Controlled		

* 3/16" (4.8 mm) maximum bulkhead thickness.

Metric Outlet Adapters

Adapts injector outlet to 4 or 6 mm tubing.

Conversion Kit Model No.	Tubing Size	Material	Nut	Ferrule
249279	4 mm	Stainless Steel	249276	249270
249280	6 mm	Stainless Steel	249275	249272
249281	4 mm	Carbon Steel	249277	249271
249282	6 mm	Carbon Steel	249274	249273

Assembly comes with one nut and one ferrule.

Feedline Brush



Model 68874

Use to apply lubricant to chains and conveyors. 1/8" NPT(F) inlet, 1" long, 5/8" surface area diameter; aluminum body with nylon bristles.

Lubricant flows through Supply Lines between the pump and injectors, then through Feed Lines between the injector and the bearing. Tubing and/or pipe sizes are determined after considering both the length of the line and the specific lubricant intended for use in the system.

Your Lincoln representative can assist you in the proper selection of supply and feed line material to optimize your application.

Listed below is a simplified outline of the installation components offered. For a complete listing of products, please refer to the Installation Components catalog.

TUBING

Hydraulic, Steel, Stainless Steel and Nylon

Single and Multiple Tube Clamps

Heavy Duty, Standard Duty, Threaded Sleeve and Snap-On Coupler Tube Fittings

Quicklinc® Tubing Adapter

Zerk-Lock™ Grease Fitting Adapters

Non-Metallic

PIPING

Seamless

Continuous Welded

Forged Fittings

Malleable Iron Fittings

316 Stainless Steel Pipe and Fittings

Stainless Steel Fittings

Galvanized Pipe, Threaded Plug and Fittings

ACCESSORIES

Supply, Feed and Bulk Feed Line Hose

Air Hose

Kits for Hose Repair

Heavy-Duty Air Line Quick Disconnects

AIR CONTROL AND ACCESSORIES

Manual Shut-Off Valves

Pressure Gauges

Lubricant Filters and Strainers

AIRCARE™ AIR PREPARATION SYSTEMS

Modular Air Line Filters, Regulators and Lubricators

Integrated/Modular Filter/Regulator with Gauge

Modular Air Line Combination Units

High Capacity Air Line Filters, Regulators and Lubricators

High Capacity Air Line Combination Units

Miniature Air Line Components—Air Line Filter, Regulator and Lubricator

Miniature Air Line Combination Units

Modular Air Line Equipment Accessories:

Lockout Valve, Quick Clamp, Quick Clamp Wall Mounting Bracket, Porting Block, Quick Mount Pipe Adapters, Manifold Block, Pressure Switch, Panel Nut, Wall Mount Bracket, Tamper Resistant Cover & Seal Wire

Air Line Equipment Accessories:

Wall Mount Bracket, High Capacity; Mounting Bracket and Nut, Miniature; Pressure Gauges

PIPE FITTINGS

Reducing Bushings

Nipples

Couplings

Reducing Couplings

Street Ells

Tees

Crosses

Adapter Unions

Elbows

Pipe Fitting Adapters

Supply Line Swivels

Feed Line Swivels

Anchor and Junction Blocks

Once you have determined your total lubricant requirements, your greatest line length, and compensated for line expansion, you're ready to determine the pump you need.

If your overall requirements are less than 2.4 cu. in. for oil or 2.15 cu. in. for grease, you can select a single stroke pump. Should your requirements demand more capacity, a reciprocating pump will fill the need.

Your Lincoln representative will suggest the best pump for you based on your application. Look over the following pages of pump selection options and feel free to ask questions.



Model 83817 Economy Grease Pump

Manual pump has metal reservoir and spring-loaded follower. Indicator pin in pump base shows when 2500 psi system operating pressure has been achieved.

Model:	83817	
Output/Stroke:	.100 cu. in.	1.6 cc
Reservoir Capacity:	1 lb.	.45 kg
	30 cu. in.	492 cc
Lube Outlet:	1/8" NPTF (F)	
Typical System	Min. 1200 psig	82 bar
Operating Pressure:	Max. 3500 psig	241 bar
Dimensions (HxWxL):	15 1/4" x 5" x 5 5/8"	387 x 127 x 141 mm
Filling Method:	14.6 oz. Grease Cartridge/Bulk Fill	



Model 1810 Grease Pump

Translucent reservoir with spring-loaded follower. Indicator pin in pump base shows when 2500 psi system operating pressure has been achieved. Refill through included fitting using Model 81834 filler pump or other manual pump equipped with Model 645006 coupler.

Model:	1810	
Output/Stroke:	.160 cu. in.	2.6 cc
Reservoir Capacity:	5 lb.	2.27 kg
	150 cu. in.	2458.50 cc
Lube Outlet:	1/4" NPTF (F)	
Typical System	Min. 1200 psig	82 bar
Operating Pressure:	Max. 3500 psig	241 bar
Dimensions (HxWxL):	16 1/4" x 7 1/8" x 7 3/4"	413 x 181 x 197 mm
Filling Method:	81834 Filler Pump	



Model 1808 Portable Grease Pump

For systems not equipped with a dedicated pump. Includes steel reservoir with follower plate, pressure gauge and 5' (1.5m) delivery hose with #68887-2 quick disconnect hydraulic coupler and one #68887-1 plug (1/2" NPTF female thread).

Model:	1808	
Output/Stroke:	.400 cu. in.	6.5 cc
Reservoir Capacity:	30 lb.	13.61 kg
	900 cu. in.	14751 cc
Lube Outlet:	3/8" NPTF (F)	
Typical System	Min. 1200 psig	82 bar
Operating Pressure:	Max. 3500 psig	241 bar
Dimensions (HxWxL):	28" x 9" x 14"	711 x 229 x 356 mm
Filling Method:	Bulk	

Centro-Matic® Integrated Pumps

All models are air-operated, positive displacement pumps delivering a maximum volume by means of a single stroke of the pump (volumes listed below). Solenoid air valves and adjustable solid-state time controls are integrated into the pump body. All pumps are designed to deliver grease to single-line injectors and include a special high volume refill fitting. Acrylic reservoirs are available in several sizes. Integrated controls feature LED indicators for “Power On”, “Pump On”, and “Alarm,” along with a membrane-type “Manual Lube” switch.



Model 85434

Model 85434 Integrated Grease Pump

Ratio:	31:1	
Power:	120 VAC	
Typical System	Min. 1200 psig	82 bar
Operating Pressure:	Max. 3500 psig	240 bar
Maximum Output:	1.4 in ³	18.7 cm ³
Reservoir Capacity:	4.5 lbs.	1.8 kg
Dimensions (LxWxH):	24.70" x 6.52" x 18.11"	627 x 166 x 460 mm

Model 85435 Integrated Grease Pump

Same as Model 85434 except 240 VAC.

Model 85436 Integrated Grease Pump

Same as Model 85434 except with a Ratio of 25:1 and Maximum Output of 2.15 in³ (35.2 cm³).

Model 85437 Integrated Grease Pump

Same as Model 85436 except 240 VAC.



Model 85442

Model 85442 Integrated Grease Pump

Ratio:	20:1	
Power:	120 VAC	
Typical System	Min. 1200 psig	82 bar
Operating Pressure:	Max. 3500 psig	240 bar
Maximum Output:	0.45 in ³	7.4 cm ³
Reservoir Capacity:	1 lb.	0.450 kg
Dimensions (LxWxH):	5.25" x 7.24" x 12.02"	133 x 184 x 305 mm

Model 85443 Integrated Grease Pump

Same as Model 85442 except 240 VAC.

Model 85444 Integrated Grease Pump

Ratio:	20:1	
Power:	120 VAC	
Typical System	Min. 1200 psig	82 bar
Operating Pressure:	Max. 3500 psig	240 bar
Maximum Output:	0.45 in ³	7.4 cm ³
Reservoir Capacity:	4 lbs.	1.8 kg
Dimensions (LxWxH):	5.25" x 7.24" x 20.75"	133 x 184 x 527 mm

Model 85445 Integrated Grease Pump

Same as Model 85444 except 240 VAC.



Model 85444

Timer and Controller Specifications

On Time	Off Time	Alarm Contacts	Operating Temperature
10 sec or 30 sec	1/2 to 30 min or 30 min to 30 hrs	8 amps @ 250 VAC	-10°F to 150°F -23°C to 165°C



Model 82886

Model 82886 Pump

Pump discharges lubricant on air-powered forward stroke and vents on spring-powered return stroke through built-in check/vent valve. Reservoir is translucent with spring-loaded follower. Includes filler fitting for refilling reservoir with Model 81834 or other manual pump equipped with Model 645006 coupler.

Model 83668

Same as Model 82886 except includes larger reservoir.



Model 83668

Model 82653 Bare Pump

Pump uses air for forward and return stroke but dispenses lubricant on forward stroke only. Return stroke vents lubricant pressure through included check/vent valve. Translucent reservoir has spring-loaded follower. Refill through included filler fitting using Model 81834 or other manual pump equipped with Model 645006 coupler.

Model 83834 High Volume Bare Pump

Same as Model 82653 except 25:1 ratio, 2.15 cu. in (35.2 cc) maximum output.

Model 82655 Pump with Controls

Same as Model 82653 except includes Model 84501 solid state timer and 350244 four way electric solenoid valve.

Model 83800 High Volume Pump with Controls

Same as Model 83834 except includes Model 84501 solid state timer and 350244 four way electric solenoid valve.

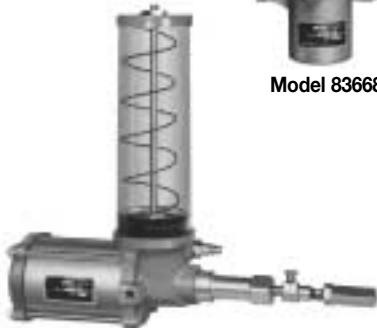

Model 82653

Model	Metric Equiv.	Lubricant /Air Ratio	Max. Output	Reservoir Capacity	Reservoir Temp. Range	Air Inlet	Lube Outlet	Lubricant Oper. Press.		Dimensions HxWxL	Air Valve Required
								Min.	Max.		
82886		20:1	.45 in ³	1 lb/.45 kg	0°F to 150°F -18°C to 65°C	1/4" NPTF(F)	1/4" NPTF(F)	1200 psig	3500 psig	10 3/8"x5 1/4"x6"	3-way
83668			7.4 cm ³	30 in ³ /492cm ³						263x133x152mm	
82653		31:1	1.4 in ³	4 lb/1.81 kg	0°F to 150°F -18°C to 65°C	(metric 1/4" BSPP)	(metric 1/4" BSPP)	82 bar	240 bar	18 1/2"x5 1/4"x6"	4-way
82655			22.9 cm ³	120 in ³ / 1967 cm ³						470x133x152mm	
83834	85393	25:1	2.15 in ³		0°F to 150°F -18°C to 65°C	(metric 1/4" BSPP)	(metric 1/4" BSPP)	82 bar	240 bar	18 1/2"x5 1/4"x21"	4-way
85393			35.2 cm ³								
83800											

Note: Air consumption @ 100 psi is .15 CFM per stroke.

Timer Specifications

Cycle Time		On Time		Power Requirements	Ambient Operating Temp. Range
Min	Max	Min	Max		
20 Sec.	24 Hr.	10 Sec.	1 Min. 24 Sec.	120 VAC, 60 hz 110 VAC, 50 hz	-10°F / -23°C to +150°F / +60°C

Note:

Refer to System Controls section for detailed timer and solenoid operated air valve specifications.



Model 83167

Includes transparent reservoir, spring-loaded follower, vent valve assembly and filler fitting for refilling of reservoir with 81834 filler pump or other manual pump equipped with Model 645006 coupler.

Model:	83167	
Lubricant/Air Ratio:	40:1	
Output/Min @ 100 PSIG Air:	12 cu. in.	197 cc
Reservoir Capacity:	12 lb. / 5.44 kg	360 cu. in. / 5900 cc
Air Inlet:	1/8" NPTF (F)	
Lube Outlet:	3/4" NPTF (F)	
Typical System	Min. 1200 psig	82 bar
Operating Pressure:	Max. 3500 psig	241 bar
Dimensions (HxWxL):	22 1/2" x 9" x 16 1/4"	572 x 229 x 413 mm
Filling Method:	81834 Filler Pump	
Reservoir:	Translucent Acrylic	

Notes: 1. Pump requires 3-way air valve. 2. Air consumption @ 100 psi is .15 CFM per cycle



Model 83599

Same as model 83167 except includes model 83744 base mounting kit and metal reservoir with indicator rod for visual check of grease level. Reservoir includes spring-loaded follower.

Model:	83599	
Lubricant/Air Ratio:	40:1	
Output/Min @ 100 PSIG Air:	12 cu. in.	197 cc
Reservoir Capacity:	12 lb. / 5.44 kg	360 cu. in. / 5900 cc
Air Inlet:	1/4" NPTF (F)	
Lube Outlet:	3/4" NPTF (F)	
Typical System	Min. 1200 psig	82 bar
Operating Pressure:	Max. 3500 psig	241 bar
Dimensions (HxWxL):	24 3/8" x 9" x 18 3/16"	619 x 229 x 462 mm
Filling Method:	81834 Filler Pump	
Reservoir:	Aluminum	

Notes: 1. Pump requires 3-way air valve. 2. Air consumption @ 100 psi is .15 CFM per cycle



Model 84050

A 50:1 ratio double acting air operated pump for high volume displacement. Supplied with a 60 pound capacity metal reservoir with removable cover for easy filling. Includes air-operated vent valve and 5' (1.5m) air and lubricant connecting hoses.

Model:	84050	
Lubricant/Air Ratio:	50:1	
Output/Min @ 100 PSIG Air:	30 cu. in.	492 cc
Reservoir Capacity:	60 lb. / 27 kg	1800 cu. in. / 29,500 cc
Air Inlet:	3/8" NPTF (F)	
Lube Outlet:	3/4" NPTF (M) at Hose	
Typical System	Min. 1200 psig	82 bar
Operating Pressure:	Max. 3500 psig	241 bar
Dimensions (HxWxL):	31 3/4" x 15 7/16" x 15 9/16"	806 x 392 x 395 mm
Filling Method:	Bulk	
Reservoir:	Steel	

Notes: 1. Pump requires 3-way air valve. 2. Air consumption @ 100 psi is .42 CFM per cycle
3. Optional Model 92597 follower available.

Model 85460

Same as Model 84050 except includes installed visual low level and follower plate assembly.



Model 1823

Includes 2½" air motor driven pump, vent valve assembly, pump elevator, connecting lubricant and air hoses, and control panel.

Model:	1823	
Lubricant/Air Ratio:	50:1	
Output/Min @ 100 PSIG Air:	30 cu. in.	492 cc
Drum Size:	U.S. standard 120 lb. refinery drum	
Air Inlet:	¾" NPTF (F)	
Lube Outlet:	¾" NPTF (F)	
Typical System	Min. 1200 psig	82 bar
Operating Pressure:	Max. 3500 psig	241 bar
Components	Pump & Vent Assembly	282288
Included:	Controller	85209
	Pump Elevator	83447
Controller Electrical Requirements:	120V, 60 Hz., 110 V, 50hz	

Notes: 1. Air consumption @ 100 psi is .42 CFM per cycle.
2. Model 83371 follower plate is available as an optional accessory.



Model 282288

Same specifications as Model 1823 but does not include elevator or controller.

Model 1827 Heavy Duty Unit

Consists of PowerMaster pump, vent valve assembly with air and lubricant connecting hoses, drum cover and control panel.



Model:	1827	
Lubricant/Air Ratio:	75:1	
Output/Min @ 100 PSIG Air:	161 cu. in.	2638 cc
Drum Size:	U.S. standard 400 lb. refinery drum	
Air Inlet:	¾" NPTF (F)	
Lube Outlet:	¾" NPTF (F)	
Typical System	Min. 1200 psig	82 bar
Operating Pressure:	Max. 3500 psig	241 bar
Components	Basic Pump	2004
Included:	Vent Valve	85215
	Controller	85209
	Drum Cover	81675

Model 1828

Same as Model 1827 except includes Model 2008 pump, 85218 vent valve and Model 84034 drum cover sized for U.S. standard 120 lb. refinery drum. Includes 85209 controller.

Model 1829

Same as Model 1827 except includes Model 2010 pump (50:1 ratio, 231 cu. in./min.(3785 cc) delivery at 100 psig air). Fits U.S. standard 400 lb. refinery drum. Includes 85209 controller and 85215 vent valve.

Model 1830

Same as Model 1827 except includes Model 2011 pump (50:1 ratio, 231 cu. in./min.(3785 cc) delivery at 100 psig air). Includes 85209 controller, 85218 vent valve and 84034 drum cover sized to fit U.S. standard 120 lb. refinery drum.





Model 1849

Fully automatic assembly including pump, 220/440 volt motor, translucent reservoir with spring-loaded follower, 4000 psi (276 bar) safety unloader, adjustable pressure switch, and time control. Time control is adjustable for lubrication cycle frequency of 5, 10, 15, 20, 30 or 60 minutes. Solid state time delay relay (35 sec. to 240 sec.) included for connection of audible or visual alarm to signal lubrication failure due to empty reservoir or broken supply line.

Model:	1849 *	
Output/Min:	18 cu. in.	295 cc
Reservoir Capacity:	12 lb. / 5.44 kg	360 cu. in. / 5900 cc
Lube Outlet:	¼" NPTF (F)	
Electrical Specifications:		
Pump Motor	220/440 VAC, 60 Hz, 3 ph	
Controller	115 VAC, 60 Hz	
Typical System	Min. 1200 psig	82 bar
Operating Pressure:	Max. 3500 psig	241 bar
Dimensions (HxWxL):	25½" x 13 "x 19½"	645 x 330 x 503 mm
Reservoir Fill Method:	81834 Filler Pump or Manual Pump and 645006 Coupler	

* See Model 85520 in Systems Control section for controller specifications.

Model 1835

Same as Model 1849 except has 115 VAC, 60 Hz motor and controller.

Model 1833

Similar to Model 1849 except: 24 VDC pump motor and controller; metal reservoir with visual level indicator rod; 2.5, 5, 10, 20, 40 and 80 minute cycle frequency adjustment; 60 second fixed on time and alarm relay features. Incorporates pressure switch factory set at 2500 psi (172 bar).



Model:	1833	
Output/Min:	18 cu. in.	295 cc
Reservoir Capacity:	12 lb. / 5.44 kg	360 cu. in. / 5900 cc
Lube Outlet:	¼" NPTF (F)	
Electrical Specifications:		
Pump Motor	¼ HP, 24 VD, 10 AMP	
Controller	24 VDC, 5 watts	
Typical System	Min. 1200 psig	82 bar
Operating Pressure:	Max. 3500 psig	241 bar
Dimensions (HxWxL):	34¼" x 11½"x 21¾"	870 x 292 x 552 mm
Reservoir Fill Method:	81834 Filler Pump or Manual Pump with 645006 Coupler	

Notes:

1. Controller has provision for remote manual lube button and remote lube failure alarm.
2. Enclosure is designed to meet NEMA 3S and 12 specifications.



Model 83742

Manual pump has metal reservoir with dip-stick fluid level indicator and filler cap and strainer. Pump base has built in check/vent valve and an indicator pin to show when system pressure is achieved.

Model:	83742	
Output/Stroke:	.360 cu. in.	5.9 cc
Reservoir Capacity:	1.4 pint / 40.4 cu. in.	.66 liter/660cc
Lube Outlet:	1/8" NPTF (F)	
Typical System	Min. 750 psig	52 bar
Operating Pressure:	Max. 1000 psig	69 bar
Dimensions (HxWxL):	14 3/4" x 5" x 5 5/16"	375 x 127 x 141 mm



Model 1812

Pump has translucent reservoir with filler cap and strainer. Pump base has built in check/vent valve and an indicator pin to show when system pressure is achieved.

Model:	1812	
Output/Stroke:	.160 cu. in.	2.6 cc
Reservoir Capacity:	4 1/2 pint /130 cu. in.	2.13 liter/2130 cc
Lube Outlet:	1/4" NPTF (F)	
Typical System	Min. 750 psig	52 bar
Operating Pressure:	Max. 1000 psig	69 bar
Dimensions (HxWxL):	16 3/4" x 7 1/8" x 7 3/4"	425 x 181 x 197 mm

Note: Check compatibility when using synthetic oils.

Centro-Matic® Integrated Pumps

All models are air-operated, positive displacement pumps delivering a maximum volume by means of a single stroke of the pump (volumes listed below). Solenoid air valves and adjustable solid-state time controls are integrated into the pump body. All pumps are designed to deliver fluid lubricants to single-line injectors and are filled via a spring-loaded filler cap and internal filter. Acrylic reservoirs are available in several sizes. Pump models 85432 and 85433 do not include a reservoir, and are designed for remote or bulk-fill oil applications (80 psi/5.4 bar maximum head pressure). Integrated controls feature LED indicators for “Power On”, “Pump On”, and “Alarm,” along with a membrane-type “Manual Lube” switch.



Model 85430



Model 85432



Model 85438



Model 85440

Model 85430 Integrated Fluid Pump

Ratio:	20:1	
Power:	120 VAC	
Typical System	Min. 750 psig	52 bar
Operating Pressure:	Max. 1000 psig	69 bar
Maximum Output:	2.4 in ³	39.3 cm ³
Reservoir Capacity:	4.5 pints	2.1 liters
Dimensions (LxWxH):	24.70" x 6.52"x 18.11"	627 x 166 x 460 mm

Model 85431 Integrated Fluid Pump

Same as Model 85430 except 240 VAC.

Model 85432 Integrated Fluid Pump

Same as Model 85430 except without reservoir.

Model 85433 Integrated Fluid Pump

Same as Model 85432 except 240 VAC.

Model 85438 Integrated Fluid Pump

Ratio:	20:1	
Power:	120 VAC	
Typical System	Min. 750 psig	52 bar
Operating Pressure:	Max. 1000 psig	69 bar
Maximum Output:	0.45 in ³	7.4 cm ³
Reservoir Capacity:	1.25 pints	0.6 liters
Dimensions (LxWxH):	5.25" x 7.24"x 12.02"	133 x 184 x 305 mm

Model 85439 Integrated Fluid Pump

Same as Model 85438 except 240 VAC.

Model 85440 Integrated Fluid Pump

Ratio:	20:1	
Power:	120 VAC	
Typical System	Min. 750 psig	52 bar
Operating Pressure:	Max. 1000 psig	69 bar
Maximum Output:	0.45 in ³	7.4 cm ³
Reservoir Capacity:	4.25 pints	2.0 liters
Dimensions (LxWxH):	5.25" x 7.24"x 20.75"	133 x 184 x 527 mm

Model 85441 Integrated Fluid Pump

Same as Model 85440 except 240 VAC.

Timer and Controller Specifications

On Time	Off Time	Alarm Contacts	Operating Temperature
10 sec or 30 sec	1/2 to 30 min or 30 min to 30 hrs	8 amps @ 250 VAC	-10°F to 150°F -23°C to 165°C

Centro-Matic® Automated Lubrication Systems

Air-Operated (Single Stroke) Oil Pumps



Model 82885



Model 83667



Model 82676

Model 82885

Pump discharges lubricant on air-powered forward stroke and vents on spring-powered return stroke through built-in check/vent valve. Translucent reservoir is refilled through filler cap with strainer.

Model 83667

Same as model 82885 except includes larger reservoir.

Model 82570

High volume pump discharges lubricant on air-powered forward stroke and vents through included check/vent valve on air-powered return stroke. Translucent reservoir is refilled through filler cap with strainer.

Model 82573

Air operated single stroke oil pump and timer assembly. Same as model 82570 except includes model 84501 solid state timer and 350244 four-way electrical solenoid valve. Power requirements: 120 VAC, 60 Hz; 110 VAC, 50 Hz.

Model 82676

Same as model 82570 except for use with external oil supply through 1/2" NPT(F) oil inlet (maximum head pressure 80 psi (5.5 bar)).

Model	Metric Equiv.	Lubricant /Air Ratio	Max. Output	Reservoir Capacity	Air Inlet	Lube Outlet	Lubricant Oper. Press.		Dimensions HxWxL	Air Valve Required
							Min.	Max.		
82885	85391	20:1	.45 in ³ 7.4 cm ³	1 1/4 pint / 6 liter 36 in ³ / 600cm ³	1/4" NPTF(F)	1/4" NPTF(F)	750 psig 52 bar	1000 psig 69 bar	10 3/8" x 5 1/4" x 6" 263x133x152mm	3-way
83667	85390		2.4 in ³ 39.3 cm ³	4 1/2 pint / 2 liter 123 in ³ / 2000 cm ³	(metric 1/4" BSPP)	(metric 1/4" BSPP)			18 1/2" x 5 1/2" x 6" 470x140x152mm	
82570	85392								17 3/4" x 5 3/4" x 18 1/4" 451x146x464mm	4-way
82573									18 1/2" x 5 3/4" x 21" 470x146x533mm	
82676				Remote						

** Air consumption @ 100 psi is .15 CFM per stroke.
Check compatibility when using synthetic oils.

Timer Specifications for Model 82573 Only

Cycle Time		On Time	
Min	Max	Min	Max
20 Sec.	24 Hr.	10 Sec.	1 Min. 24 Sec.

Note:

Refer to System Controls section for detailed timer and solenoid operated air valve specifications.



Model 283167

Includes 2½" air motor driven pump, vent valve assembly, translucent reservoir with filler cap and strainer, and 1200 psi (82 bar) safety unloader.

Model:	283167	
Lubricant/Air Ratio:	40:1	
Output/Min @ 100 PSI Air:	12 cu. in.	197 cc
Reservoir Capacity:	15 pint	7.1 liter
	433 cu. in.	7100 cc
Air Inlet:	½" NPTF (F)	
Lube Outlet:	¾" NPTF (F)	
Typical System	Min. 750 psig	52 bar
Operating Pressure:	Max. 1000 psig	69 bar
Dimensions (HxWxL):	23¼" x 9" x 16¼"	591 x 229 x 413 mm
Air Valve Required:	3-Way**	

** Air consumption @ 100 psi is .15 CFM per stroke.

Note: Check compatibility when using synthetic oils.



Model 1826

Consists of Model 2002 PowerMaster pump, Model 85217 vent valve assembly, Model 81675 drum cover, Model 85209 controller, air and lubricant connecting hoses, and 1200 psi (82 bar) safety unloader.

Model:	1826	
Lubricant/Air Ratio:	24:1	
Output @ 75 Cycles/Min:	462 cu. in.	7571 cc
Drum Size:	U.S. standard 55 gal. refinery drum (removable head)	
Air Inlet:	¾" NPTF (F)	
Lube Outlet:	¾" NPTF (F)	
Typical System	Min. 750 psig	52 bar
Operating Pressure:	Max. 1000 psig	69 bar
Controller Electrical		
Requirements:	120 V 60 Hz, 110V 50 Hz	

Notes:

1. See System Controls section for detailed controller specifications.
2. See Industrial Pumping catalog for basic pump specification, including air consumption.

Model 201826

Same as Model 1826 except includes Model 2003 40:1 ratio PowerMaster pump. Output at 75 CPM is 277 cu. in. (4539 cc).



Model 1848

Fully automatic assembly including pump, 220/440 volt motor, translucent reservoir, 1200 psi (82 bar) safety unloader, adjustable pressure switch and time control. Time control is adjustable for lubrication cycle frequency of 5, 10, 15, 20, 30, or 60 minutes. Solid state time delay relay (35 sec. to 240 sec.) included for connection of audible or visual alarm to signal lubrication failure due to empty reservoir or broken supply line.

Model:	1848	
Output/Min:	18 cu. in.	295 cc
Reservoir Capacity:	14.7 pint	6.96 liter
	424 cu. in.	6960cc
Lube Outlet:	¼" NPTF (F)	
Electrical Specifications:		
Pump Motor	220/440 VAC, 60 Hz, 3 ph	
Controller Max..	115 VAC, 60 Hz	
Typical System	Min. 750 psig	52 bar
Operating Pressure:	Max. 1000 psig	69 bar
Dimensions (HxWxL):	25¾" x 13 "x 19 ¹³ / ₁₆ "	645 x 330 x 503 mm

Note: See #85520, System Controls section for controller specifications.

Hydraulically-Operated (Single Stroke) Oil Pumps



Model 1820

Designed for applications utilizing a remote mounted lubricant reservoir. Fluid lubricants only. Requires hydraulic flow for forward and return stroke. Pump includes lubricant and hydraulic cylinders and automatic vent valve.

Model:	1820	
Lubricant/Hydraulic Ratio:	5.75:1	
Maximum Output:	2.8 cu. in.	45.9 cc
Reservoir:	None	
Hydraulic Inlet/Outlet:	⅜" NPTF (F)	
Lube Inlet:	¾" NPTF (F)	
Lube Outlet:	⅜" NPTF (F)	
Typical System Operating Pressure:	Factory Set @ 2500 psi (172 bar) Max.	
Dimensions (HxWxL):	4" x 5¾" x 12"	102 x 146 x 305 mm
Hydraulic Pressure	Min. 450 psig	31 bar
Requirement:	Max. 2000 psig	138 bar

Note: Requires user-supplied 4-way hydraulic supply valve.



Reservoir Low-Level Alarm Kits

Low level kits signal need to fill reservoir.

Model	Lubricant Type	Use with Models	Switch Type	Switch Capacity Voltage (Amps)	Features
83671	Grease	82653, 82655, 83668, 83800, 83834, 83167 83599, 1833, 1835, 1849 85434, 85435, 85436 85437, 85442	SPDT	125 VAC (15) 250 VAC (15) 480 VAC (15) 24 VDC (2) 125 VDC (1/2) 250 VDC (1/4)	Connect to machine control or visual/audible alarm circuit.
83696	Oil	82570, 82573, 83667, 283167, 1848, 85430 85431, 85432, 85433 85438, 85439, 85440, 85441			
84629	Grease	84960			
85490	Grease	84050	None	—	Includes follower, visual indication only.
249608	Grease	84050 new style			

Follower Plates

Recommended when pumping lubricants that do not readily seek their own level.



Model	Use with Pump Models	Container Size
83370	1827, 1829	Standard U.S. 400 lb. refinery drum
83371	1823, 282288, 84960	Standard U.S. 120 lb. refinery drum
92544	1828, 1830	Standard U.S. 120 lb. refinery drum
92597	84050, 84944	Lincoln 60 lb. container
252725	85483	Lincoln 35 lb. unit
85489	85481	Lincoln 60 lb. unit

Automatic Filling System Pressure Regulator

Pressurized systems automatically keep up to eight single stroke oil pump reservoirs full at all times. Use with reservoir seal kits below. Fill pump not included.



Model	Fill Pump Requirements		Fill System Requirements		Reservoir Pressure psig / bar	Lubricant Inlet/Outlet	Vent Outlet
	Max. * psig / bar	Max. Ratio	Max. Length				
			5/8" Tube	3/4" Tube			
83372	125 / 8.6	3:1	100' / 30.5m	55' / 16.8m	5 / .34	1/2" NPT(F)	1/4" NPT(F)

* Indicates maximum lubricant output pressure.

Pressure Kits

Seal reservoirs for automatic filling.

Model	Use with Pump Models
83368	82885
83637	82570, 82573



Manual Filling Pumps

Designed to provide a fast, clean method of filling Centro-Matic pumps with a self-contained reservoir without the risk of lubricant contamination.

Model	Lubricant Type	Lubricant Output	Container Capacity	Hose Length	Lubricant Outlet	Dimensions - in. / mm		
						Height	Width	Container Diameter
81834	Grease NLGI #1 Max	1 oz/stroke 1.9 cu. in. 31 cc	30 lbs. 14.2 L	7' 2.1 m	645006 Hydraulic Coupler	26¾ 679	14 356	9 229
1254	Oil	1 pint/ 7 strokes 473 cc	30 pints 14.2 L	5' 1.5 m	80599 Non-Drip Nozzle			



Metal Reservoirs: Rectangular reservoirs for gravity feed oil pumps

Standard ¾" NPTF outlet furnished for gravity-fed pumps. Features spring loaded cap with strainer, sight gauge and Buna-N O-rings. Model 84376 Sight Gauge Kit available for use with synthetic oil.

Model	Capacity		Lubricant Outlet	Dimensions					
	Gal	Liter		Height		Width		Depth	
				in	mm	in	mm	in	mm
87417	5	19	¾" NPTF (F)	10⅞	257	17½	446	12½	318
87418	3	11.4				13½	343	11½	292
87419	1.5	5.7				10½	267	7½	191



Cylindrical Reservoir

Four gallon steel tank type reservoir consisting of model 82700 tank and model 82612 mounting brackets. Incorporates large filler opening with screw cap.

Model	Tank Number	Bracket Number	Capacity	Lubricant Outlet	Dimensions - in. / mm	
					Height	Diameter
82621	82700	82612	4 gal./15.1L	½" NPT (F)	18 / 457	9 / 229

Centro-Matic® Automated Lubrication Systems

FlowMaster™ Hydraulic Pump



High-performance FlowMaster hydraulic pumps combine rotary-driven pump motors with reciprocating pump tubes and flexible control features that perform in desert heat and arctic cold. Integrated control manifold adjusts the amount of lubricant and operating pressure. The pump's output is adjustable from 7 to 45 cubic inches per minute.

Supply Inlet Hydraulic Pressure, Max.:	3000 psig	200 bar
Operating Inlet Hydraulic Pressure:	300 to 420 psig	20 to 32 bar
Hydraulic Inlet Flow:	Up to 7 gpm	28 l/min
Pump Ratio with Manifold:	9:1 at low inlet pressure (300 to 350 psi/20 to 25 bar) and low inlet flow (below 2 gpm/7 lpm) pump ratio approaches 11:1 ratio at higher inlet pressure and flow	
Operating Temperature:	-20° to +150°F	-10° to +65°C
Operating Voltage:	24 VDC	
Hydraulic Inlet Port:	3/8" NPTF	
Tank Return Port:	3/8" NPTF	
Pump Outlets:	1/4" NPTF	
Max. Hydraulic Fluid Temp:	130°F	55°C

For the complete system as shown, when ordering 120# or 400# versions also order the following:

120#	Drum Cover	84616
	Follower Assy	85492
	Vent Valve Assy	84990
400#	Drum Cover	271606
	Follower Assy	270982
	Vent Valve Assy	271605

Model	Description	Dimension A in. / mm	Dimension B in. / mm
85487	60 lb. pump assembly for Centro-Matic	19.90 / 505	29.70 / 743
86258	60 lb. pump assembly with low level and follower plate for Centro-Matic	19.90 / 505	29.70 / 743
85482	Pump for 400 lb. drum (55 gallon)	34.00 / 864	43.81 / 1113
85480	Pump for 120 lb. drum (18 gallon)	27.50 / 699	37.31 / 948
85481	Pump for 60 lb. canister (8 gallon)	19.00 / 483	28.81 / 732
85483	Pump for 35 lb. pail (5 gallon)	13.69 / 348	23.50 / 597

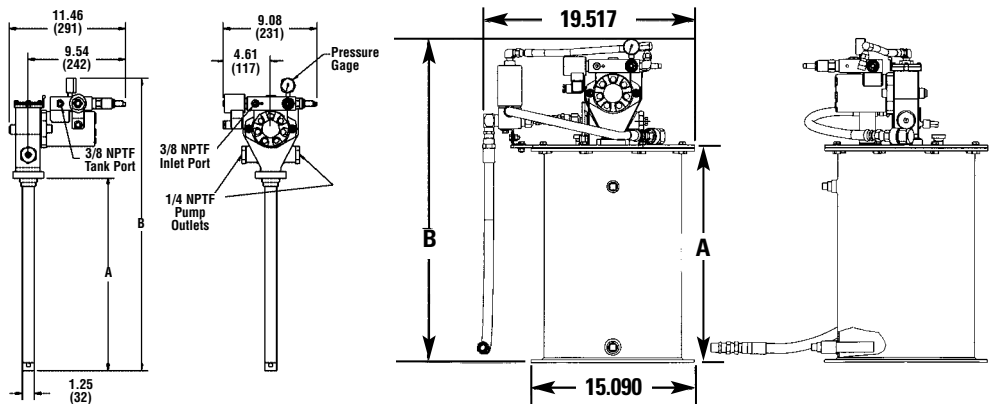

Enhanced low level indicator eliminates false low level signals

Special coupling to easily remove the pump from the vent valve before servicing

Thick rubber seal to keep contaminants out

Aircraft cable to strengthen connection between low level and follower plate

Wiper on follower plate to better wipe off the grease from the sides

Stop bolts on follower plate to prevent cocking

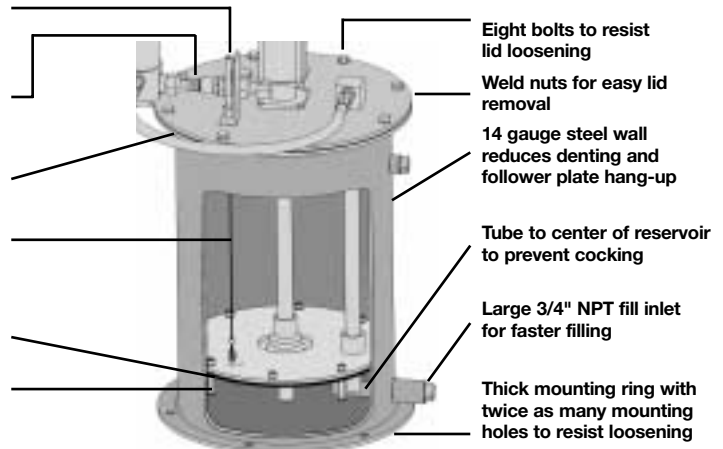

Eight bolts to resist lid loosening

Weld nuts for easy lid removal

14 gauge steel wall reduces denting and follower plate hang-up

Tube to center of reservoir to prevent cocking

Large 3/4" NPT fill inlet for faster filling

Thick mounting ring with twice as many mounting holes to resist loosening

Model 84944

Hydraulic operated pump with 60 lb. metal reservoir and vent valve.

Model:	84944	
Nominal Lubricant/ Hydraulic Pressure Ratio:	16:1	
Output/Min @ 30 Cycles/Min:	11 cu. in.	180 cc
Reservoir Capacity:	60 lb. / 27 kg	1800 cu. in. / 29,500 cc
Hydraulic Inlet/Outlet:	¼" NPTF (M)	
Lube Outlet:	¾" NPTF (M)	

Important Note:

1. Pumps require a timed electrical signal to operate. Use Model 244270 Cycle Timer. See System Controls section for specifications.
2. Included hydraulic solenoids require 24 VDC.

Model 84961

Basic pump only for Model 84944. Includes pump and hydraulic control. Does not include reservoir or vent valve.

Model 84960

Hydraulic pump for use with U.S. standard 120 lb. refinery drum. System components (pump, vent assembly, drum cover and follower plate) must be ordered separately.

Model 84962

Hydraulic pump for custom lubricant container installations. Pump length is sized for U.S. standard 400 lb. refinery drum depth.

Model	Nominal Lubricant/ Hydraulic Pressure Ratio	Output/Min @ 30 Cycles/Min	Lube Outlet	Pump Tube Length	Pump Tube Diameter
84960	16:1	11 in ³ / 180 cm ³	¼" NPTF(F)	—	—
84962				33 ¹⁵ / ₁₆ " 862 mm	1" 25.4 mm

Important Note:

1. Pumps require a timed electrical signal to operate. Use Model 244270 Cycle Timer. See System Controls section for specifications.
2. Included hydraulic solenoids require 24 VDC.
Use Vent Assembly Model 84990; Drum Cover Model 84616 and Follower Plate Model 83371.
Drum Cover and Follower Plate are for use with Model 84960 only.

Hydraulic Power Supply Requirements

Hydraulic Inlet Pressure psig / bar		Flow Rate @ 30 Cycles/Min. GPM ltrs/min	Fluid Max. Inlet Temperature	Ambient Operating Temperature Range		Filtration Requirement
Min	Max			Min	Max	
300 / 21	3000 / 207	1.0 / 3.8	210°F/99°C	-40°F/-40°C	+135°F/57°C	10 Micron

Note: All pumps have a hydraulic pressure reducing valve rated for 60 psi (4 bar) to 800 psi (55 bar) output. Maximum input is 3000 psi (207 bar).



Ultrasonic High/Low Sensor to make it easier to know when the 60 lb. Centro-Matic® automated lubrication system reservoir is getting low on lubricant and when it's refilled to capacity. Sensor detects the position of the follower plate with ultrasonic waves to report the lubricant level. The sensor, factory programmed for the 60 lb. reservoir, is available on either air-operated reciprocating or FlowMaster™ rotary-driven hydraulic pumps. Its two outputs drive external signaling devices or connect with a customer's PLC. Three standard LEDs offer visual indication of the sensor's status and reservoir level.

Ambient Temperature Range:	-13°F to 158°F (-25°C to 70°C)
Protection:	IP65
Power Supply Operating Range:	20 - 30 VDC
Current (less load):	60 mA
Switching Outputs:	
Maximum Current:	200 mA
High Level:	NO contact (closes when full)
Low Level:	NO contact (opens when low)

Centro-Matic Pump Assemblies with 60 lb. Reservoir & Ultrasonic Level Sensor

Model	Operation	Refer to Basic Model for Pump & Reservoir Detail
85465	Pneumatic	84050
85470	Hydraulic	85487

Selecting the right controls for your automated lubrication system is one of the last steps in the design process. Several different models may be chosen to control power-operated pumps, depending on the degree of automation and monitoring required. Your Lincoln representative will assist you in specifying the correct model.

Options range from simple timers to fully automated system controllers and monitors. Basic timers allow you to set the interval between lubrication cycles. More sophisticated monitors control the frequency of lubrication, oversee system performance, and can sense lubricant flow to each bearing while showing system status and alarms on a LCD display panel. Monitors may be interfaced with machine control systems to protect your equipment from harm.

You may customize your installation with air and lubricant filters to prolong system life, pressure gauges for monitoring, shut-off valves to ease future maintenance, and even automated filling systems to utilize bulk lubricant storage.

All of these possibilities, and more, have made Lincoln Automated Lubrication Systems the choice of industry for over 80 years.



Model 84501 Program Timer—Solid State

Designed to control the lubrication cycle frequency of air operated single stroke pumps. Timer turns pump on/off at programmed intervals via a 3-way or 4-way air solenoid valve (not included) installed in the air line to pump.

Off Time (Cycle Time)		On Time (Pumping Time)		Power Requirements	Approvals	Switch Capacity
Min	Max	Min	Max			
20 Sec.	24 Hrs.	10 Sec.	1 Min. 24 Sec.	120/230 VAC 50/60 Hz	UL, CSA	120 VAC, 5 Amps 230 VAC, 1.5 Amps



Built-In Program Options				Enclosure			Ambient Operating Temperature Range		
3 Hr. Program Memory		Prelube Function		Rating	Dimensions-in./mm			Minimum	Maximum
Yes	No	Yes	No		Height	Width	Depth		
Yes	No	Yes	No	NEMA #1	8¼ 210	6¼ 173	4¼ 125	0°F -18°C	130°F 54°C

Note:

Refer to Technical Manual for a full explanation of available program options.



Model 84511 Economy Timer for Single Stroke Pumps

Uses a timing motor, cam and switch to turn pump off and on. NEMA 1 enclosure, UL and CSA listed. Switch capacity 10 amps non-inductive.

Off Time (Cycle Time)		On Time (Pumping Time)		Power Requirements	Approvals	Switch Capacity
Min	Max	Min	Max			
5 Min.	1 Hr.	30 Sec.	90 Sec.	120 VAC, 60 Hz	UL, CSA	10 Amps

Note: Off-time selectable in 5 minute intervals.

Enclosure			
Rating	Dimensions - in. / mm		
	Height	Width	Depth
NEMA 1	5 / 127	3¼ / 82.5	3½ / 89



Model 84015 Timer—12-24V DC

Solid-state microprocessor based controller for automated lubrication systems on mobile equipment or where AC power is not available. Rugged construction with liquid and dust-tight enclosure. Includes manual push button for remote initiation of a lube cycle.

Off Time** (Cycle Time)		Fixed On Time (Pumping Time)	Power Requirements	Switch Capacity
Min.	Max.			
2.5 Min.	80 Min.	75 Sec.	10-30 VDC 25 MA*	5 Amps

* Less load.

** Available selections are 2.5, 5, 10, 20, 40 or 80 minutes.

Enclosure				Ambient Operating Temperature Range	
Rating	Dimensions-in. / mm			Minimum	Maximum
	Height	Width	Depth		
NEMA 12	5¼ / 133	3⅞ / 79	3 / 76	0°F / -18°C	131°F / 55°C



Model 85520 Programmable Controller

Microprocessor-controlled, 120 volt AC unit is fully programmable. Controller has a wider off-time range than timers, features an adjustable pressure switch (280-3000 psi) and a memory switch to turn pre-lube option on or off.

Off Time (Cycle Time)		On Time (Pumping/ AlarmTime)		Power Requirements	Switch Capacity Inductive Load at 30VDC	
Min.	Max.	Min.	Max.		Load Relay	Alarm Relay
30 Sec.	30 Hours	30 Sec.	2 Min.	21-30 DC 100 MA*	2 Amps	2 Amps

Enclosure				Ambient Operating Temperature Range	
Rating	Dimensions-in. / mm			Minimum	Maximum
	Height	Width	Depth		
NEMA 12	7½ / 191	4⅝ / 125	3½ / 89	0°F / -18°C	130°F / 55°C

* Less load.

Model 85525 Programmable Controller

Same as model 85520 except includes pressure switch and mounting brackets.

Model 85535 System Controller—24V DC

Same as Model 85520 except is a 24 volt DC.



Model 85530 Lubrication System Controller

Controls lubrication frequency and monitors supply line pressure. The LCD displays operating status.

Lube Cycle				Max. Count Rate*	Pumping Time Before Alarm	
Timer Mode Off-Time		Counter Mode Off-Counts			Min.	Max.
Min.	Max.	Min.	Max.			
1 Minute	9,900 Minutes	1 Count	99,000 Counts	30/Sec. @ 50% Duty Cycle	1 Minute	99 Minutes

* Minimum duration of count signal is 33 milliseconds.

Power Requirements (less load)		Pump, Solenoid, or Alarm Capacity	Ambient Temperature Range	Rating	Enclosure Dimensions-in. / mm		
Voltage	Current				Height	Width	Depth
120 VAC, 50/60 Hz	85 MA	360 VA	32° to 122°F 0° to +50° C	NEMA 12	9½ 241	8⅝ 227	4⅝ 105
230 VAC, 50/60 HZ	45 MA						
24 VDC	250 MA	5 Amps					

Note: Model 85530 is CSA/NRTL approved.



Model 85209 Panel Mounted Pneumatic Control System

Panel Mounted units control lubrication frequency and monitor supply line pressure. Includes Model 85530 Controller (specifications above), Model 69630 Pressure Switch and solenoid operated air valve.

Lube Cycle				Max. Count Rate	Pumping Time Before Alarm		Connections	
Timer Mode Off Time		Counter Mode Off Counts			Min.	Max.	Air	Lube
Min.	Max.	Min.	Max.					
1 Minute	9,900 Minutes	1 Count	99,000 Counts	30/ Sec.	1 Minute	99 Minutes	¾" NPTF(F)	¾" NPTF(F)

Power Requirements		External Alarm Load Capacity	Ambient Temperature Range	Panel Dimensions in. / mm	
Voltage	Current (less load)			Height	Width
120 VAC, 60 Hz 110 VAC, 50 Hz	47 VA	360 VA	32° to 122°F 0° to +50°C	12 305	18¼ 464

Model 85208

Same as Model 85209 except 220 VAC, 50-60 Hz power.



Model 85500 System Sentry II

The ultimate automated lubrication system controller/monitor now features greater monitoring accuracy with less sensitivity to lubricant flow rates, feed line length, or bearing back pressure. System Sentry II is always on the job, making sure that every lube point is lubricated when it's supposed to be.

- Solid-state controller with LCD status display and 16-button keypad for system programming
- Controls up to two pumps with as many as two lube zones per pump
- Fully programmable monitoring and alarm functions
- Be set up to monitor every lube point for lubricant flow during each lubrication event
- Easy to understand prompts reported by simple English language messages in real time

Some functions require optional accessories. See chart on page 37. Use a maximum of 48 sensors and three accessory Sensor Boards (order separately— 16 sensors per board) to monitor lube points. For more than 48 sensors, use Model 85510 Satellite plus additional Sensor Boards for a maximum of 1536 lube points.

Lube Cycle				Max. Count Rate*	Pumping Time Before Alarm		Net Wt.
Timer Mode Off-Time		Counter Mode Off-Counts			Min.	Max.	
Min.	Max.	Min.	Max.				
1 Second	9,900 Minutes	1 Count	99,000 Counts	30/Sec. @ 50% Duty Cycle	1 Second	99 Minutes	18 lbs. 8.1 kg

* Minimum duration of count signal is 33 milliseconds.

Power Requirements (less load)		Pump, Solenoid, or Alarm Capacity	Ambient Temperature Range	Rating	Enclosure Dimensions-in. / mm		
Voltage	Current				Height	Width	Depth
120 VAC, 50/60 Hz	250 MA*	360 VA	32° to 122°F 0° to +50° C	NEMA 12	11 241	14 227	4 105
230 VAC, 50/60 HZ	125 MA*						
24 VDC	600 MA*	5 Amps					

Note: Model 85500 is CSA/NRTL approved.

* No external load, no sensors.

Model 85510 Satellite Monitor

Add-on unit to be used with Model 85500 System Sentry II when monitoring more than 48 lube points. Includes one 250365 Sensor Board capable of monitoring up to 16 lubrication points. Accepts up to two more optional Sensor Boards.

Has external power-on light and jack for four contact modular phone cord to connect Satellite to System Sentry II and additional Satellite units in “daisy chain” configuration. Maximum length of four contact flat phone cord is 4000 feet. Same size and appearance as Model 85500, except without keypad and display.



Input Voltage	Current Consumption (48 Sensors)	Controller Temp.	Net Weight	Dimensions-in. / mm			
				Enclosure	H	W	D
120 VAC, 50/60 Hz 230 VAC, 50/60 HZ 24 VDC	400 MA @ 120 VAC 200 MA @ 230 VDC 1.5 AMP @ 24 VDC	0° to 130° F -18° to 54° C	18 lbs. 8.1 kg	NEMA 12	11 241	14 227	4 105

Note: Model 85510 is CSA/NRTL approved.



Model 247333 Pressure Transducer

Pressure Transducer signals actual system pressure via LCD display of System Sentry II. Comes with 72 inch (1.8m) shielded 24-gauge connecting wire. Maximum length of wire between transducer and monitor is 30 (9.1m) feet.

Range	Accuracy	Proof	Pressure Connection	Ambient Temp.	Input	Voltage Output	Offset	Enclosure
0 to 4000 psi 276 bar	±1%	7500 psig 517 bar	¼" NPT Male Thread	-20° to 180° F -29° to 82° C	10 to 30 VDC	1-6 VDC	1 VDC	NEMA 4X Rating 300 Series Stainless Steel

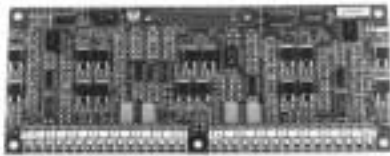

Model 250365 Sensor Board

Plug-in accessory board used with Model 85500 and Model 85510 that allows the attachment of up to 16 lube flow sensors. (Model 85500 comes without boards installed and can hold up to a total of three. Model 85510 comes with one board installed and can hold up to two more for a total of three.)

Sensor Assemblies

Sensor assemblies consist of a check body and lube sensor with attached 30' cable. Cables are epoxy potted into the sensors for a watertight seal. Sensors have a 3/8" pipe thread for conduit connection and a Viton o-ring seal. Check bodies terminate in a 1/8" NPTF male thread for attachment to a bearing or other lubricant inlet. Maximum working pressure 6,000 psi (414 bar). Maximum wire run from sensor to monitor is 500 feet (152m).



Model	Description	Construction	Lubricant Temp. Range	Min. Flow Per Event	Inlet/Outlet	Min. Interval Between Lube Flow Event
250400	Straight Sensor Assembly	Brass Sensor & Plated Steel Check Body	32° to 145° F 0° to 63° C	.004 cu. in. / .066 cc @ 32°F / 0° C to 125°F / 52°C	1/8"	30 Seconds
250490	90° Sensor Assembly					
250500	Straight Sensor Assembly	Sensor & Check Body	.008 in³ / .131cc @ 126°F / 53°C to 145°F / 63°C			
250590	90° Sensor Assembly	316 Stainless Steel				

Model 243100 Sensor Wire

100 foot (30.5 meters) coil of 2 conductor 22 gauge wire for connecting sensors to monitor. Maximum length of wire between sensor and monitor is 500 feet (152 meters).



Use this guide to select accessories for Model 85500 System Sentry II

Function	Pressure Switch #69630	Pressure Transducer #247333	Sensor Board #250365	Sensors Note 2	Sensor Wire #243100 (100') Note 3	Satellite Monitor #85510 Note 4
Lube Controller 1 Pump, 1 Zone <i>Note 1</i>	Optional 1	Optional 1	—	—	—	—
Lube Controller, 1 Pump, Up to 3 Zones	Required 1 per Zone (3 Max.)	Required 1	—	—	—	—
Lube Controller, 2 Pumps, 1 Zone Per Pump	No	Required 2 (1 per Pump)	—	—	—	—
Lube Controller, 2 Pumps, Up to 2 Zones Per Pump	Required 1 per Zone (4 Max.)	Required 2 (1 per Pump)	—	—	—	—
Lube Point Monitoring ≤ 48 Points	—	—	Required 1 per each 16 Sensors	Required 1 per Lube Point	Required Quantity As Needed	—
Lube Point Monitoring > 48 ≤ 1536 Points	—	—	Required 1 per each 16 Sensors	Required 1 per Lube Point	Required Quantity As Needed	Required Quantity As Needed

Note 1: Controller may be operated without a pressure switch or pressure transducer but will not be able to monitor and alarm for lube system pressure failures.

Note 2: Sensors include 30' (9.1m) cable pigtail. Select brass/plated steel or stainless steel sensors in straight or 90° configuration as required.

Note 3: Maximum distance between monitor and sensor is 500' (152 meters).

Note 4: Satellite monitor includes one 250365 sensor board and accepts two additional boards (optional) for connection of up to 48 sensors per satellite. Maximum 31 satellites per system.



Electric Solenoid Operated Air Valves

Model	Type	Electrical Characteristics			Air Inlet/Outlet	Ambient Temperature Range	Cv Factor	Max. Pressure psi / bar	Conduit Connection
		Power Requirements	Inrush Current Amps	Holding Current Amps					
350244	4-Way	110 VAC, 50 Hz 120 VAC, 60 Hz 8.4 VA	.11	.07	1/4" NPT(F)	0° to 120°F -18° to 49°C	1.2	150 10.3	1/2" NPS(F)
350245		220 VAC, 50 Hz 240 VAC, 60 Hz 8.4 VA	.055	.035					
350241	3-Way	110 VAC, 50 Hz 120 VAC, 60 Hz 8.4 VA	.11	.07	1/8" NPT(F)	0° to 140°F -18° to 60°C	1.8	150 10.3	N/A
350242		220 VAC, 50 Hz 240 VAC, 60 Hz 8.4 VA	.055	.035					
350282		12 VDC 6 Watts	N/A	N/A					
350283		24 VDC 6 Watts							
68586	2-Way	120V, 60 Hz 12 VA	.2	.1	3/8" NPT(F)		2.4		1/2" NPT(F)



Model 249605 Sealed Cycle Timer

Sealed timer attaches to Lincoln 16:1 Hydraulic Pumps and generates timed pulse signal to control pump reciprocating cycle rate.

Power Requirement	Cycle Rate/Minute	
	Min.	Max.
24 VDC	6	60



Model 84360 System Alarm

System Alarm includes Model 84297 Reset Timer and Model 69630 Pressure Switch. Signals alarm if system pressure is not detected within preset intervals.

Power Requirement (less load)	Count Down Interval Before Alarm Signal		Reset Timer Enclosure	Lube Connection	Increasing Pressure Switch Adjustment psi / bar	
	Min.	Max.			Min.	Max.
115 VAC, 60 Hz 7.5 VA	9 Min.	5 Hours	NEMA 1	1/4" NPT(F)	280 / 19	3000 / 207



End-of-Line Monitors

Designed to detect system pressure utilizing normally open or normally closed switch.

Model	Switch Rating	Operating Range - psig / bar		Lube Inlet	Dimensions - in / mm		Conduit Connection
		Min.	Max.		Height	Width	
83898	125, 250	1200 / 83	2500 / 172	¼"	5¾ / 146	2¼ / 57	½" NPSM
83899	480 VAC, 15 Amps	700 / 48	1150 / 79	NPT(F)			



Model 83354 Signal Monitor

Designed to provide visual and audible indication of system operation and failure. Utilizes signal from system controller. Includes model 69606 Alarm Horn mounted on enclosure door.

Power Requirement	Indicator Lamps			Audible Alarm	Dimensions - in / mm		
	Power On	Lube System On	System Failure		Height	Width	Depth
115 VAC 50/60 Hz 35 VA	Green	Amber	Red	69606 Horn (included)	10 254	8 203	6 152

Note: Lamps and horn are U.L. listed.

Model 69606 Alarm Horn

Use with controllers or System Alarm Model 84360 for audible failure signal.

Model	Power Requirement
69606	120 VAC, 50/60 Hz, 15 VA

Note: U.L. listed.



Model 69630 Pressure Switch

Senses supply line pressure rise/fall to signal system operation to controller or system alarm.

Type	Switch Capacity		Adjustable Range - psig / bar				Connections	
	AC	DC	Decreasing		Increasing		Lube	Electrical
			Min.	Max.	Min.	Max.		
Single Contact	10 Amps at 125, 250 or 480 VDC	15 Amps @ 6 VDC 5 Amps @ 24 VDC .03 Amps @ 250 VDC	250 17	2775 191	280 19	3000 207	¼" NPT(F)	7/32" hole for ½" conduit connector

Note: Pressure switch has a NEMA 3 housing and UL listed switching elements.

<u>Part No.</u>	<u>Page No.</u>	<u>Part No.</u>	<u>Page No.</u>
1254.....	28	68586.....	37
1808.....	16	68587.....	14
1810.....	16	68874.....	14
1812.....	22	68887-1.....	16
1820.....	26	68887-2.....	16
1823.....	20, 27	69456.....	14
1826.....	25	69606.....	39
1827.....	20, 27	69630.....	34, 37, 37, 39
1828.....	20, 27	80599.....	28
1829.....	20, 27	81646.....	13
1830.....	20, 27	81675.....	20, 25
1833.....	21, 27	81713.....	6
1835.....	21, 27	81713A.....	6
1848.....	26, 27	81770-1.....	6
1849.....	21, 27	81770-2.....	6
2002.....	25	81770-3.....	6
2003.....	25	81770-4.....	6
2004.....	20	81770-5.....	6
2008.....	20	81770-6.....	6
2010.....	20	81834.....	28
2011.....	20	82272.....	14
12511.....	14	82294-1.....	10
12511-9.....	14	82294-2.....	10
12698.....	14	82294-3.....	10
12698-9.....	14	82294-4.....	10
14988.....	13	82294-5.....	10
14991.....	13	82295.....	10
66260.....	14	82570.....	24, 27
66260-9.....	14	82573.....	24, 27
66713.....	14	82621.....	28
67007.....	14	82653.....	18, 27
67007-9.....	14	82655.....	18, 27
67044.....	14	82676.....	24
68421.....	14	82700.....	28
68483.....	13	82885.....	24, 27

<u>Part No.</u>	<u>Page No.</u>	<u>Part No.</u>	<u>Page No.</u>
82886	18	83637	27
83167	19, 27	83660	9
83272	13	83661-1	9
83309-1	4	83661-2	9
83309-2	4	83661-3	9
83309-3	4	83661-4	9
83309-4	4	83667	24, 27
83309-5	4	83668	18, 27
83309-6	4	83671	27
83311-1	8	83696	27
83311-2	8	83715-1	4
83311-3	8	83715-2	4
83311-4	8	83715-3	4
83311-5	8	83715-4	4
83311-6	8	83715-6	4
83311-10	8	83715-7	4
83311-15	8	83724-1	5
83313	8	83724-2	5
83314	4	83724-3	5
83314-9	4	83724-4	5
83336-1	5	83730	13
83336-2	5	83742	22
83336-3	5	83744	19
83336-4	5	83748	11
83337-9	5	83749-1	11
83337	5	83749-2	11
83338	5	83749-3	11
83354	39	83749-4	11
83368	27	83749-5	11
83370	27	83800	18, 27
83371	20, 27, 30	83817	16
83372	27	83834	18, 27
83447	20	83898	39
83535	8	83899	39
83599	19, 27	83900	4

<u>Part No.</u>	<u>Page No.</u>	<u>Part No.</u>	<u>Page No.</u>
83900-9	4	84961	30
83924	14	84962	30
83924-9	14	84990	29, 30
84015	33	85208	34
84034	20	85209	20, 25, 34
84048	8	85215	20
84050	19, 27, 31	85217	25
84110	9	85218	20
84195	13	85351-1	12
84200	13	85351-2	12
84203	13	85351-3	12
84204	14	85351-4	12
84297	37	85351-5	12
84360	37, 39	85351-6	12
84376	28	85352-1	12
84428-1	8	85352-2	12
84428-2	8	85352-3	12
84428-3	8	85352-4	12
84428-4	8	85352-5	12
84428-5	8	85352-6	12
84428-6	8	85353-1	12
84428-10	8	85353-2	12
84428-15	8	85353-3	12
84429-1	9	85353-4	12
84429-2	9	85390	24
84429-3	9	85391	24
84429-4	9	85392	24
84501	18, 24, 32	85393	18
84511	32	85430	23, 27
84616	29, 30	85431	23, 27
84629	27	85432	23, 27
84776	6	85433	23, 27
84825	13	85434	17, 27
84944	27, 30	85435	17, 27
84960	27, 30	85436	17, 27

<u>Part No.</u>	<u>Page No.</u>	<u>Part No.</u>	<u>Page No.</u>
85437	17, 27	87418	28
85438	23, 27	87419	28
85439	23, 27	90537	13
85440	23, 27	92544	27
85441	23, 27	92597	19, 27
85442	17, 27	102781	13
85443	17	201826	25
85444	17	239351	6
85445	17	239352	6
85451	6	239353	6
85452	6	239354	6
85453	6	239355	6
85454	6	243100	35, 37
85455	6	244270	30
85456	6	246965	6
85460	19	247333	35, 37
85465	31	249270	14
84570	31	249271	14
85480	29	249272	14
85481	27, 29	249273	14
85482	29	249274	14
85483	27, 29	249275	14
85487	29, 31	249276	14
85489	27	249277	14
85490	27	249279	13, 14
85492	29	249280	13, 14
85497	7	249281	13, 14
85500	35, 36, 37	249282	13, 14
85510	35, 36, 37	249605	38
85520	33	249608	27
85525	33	250365	35, 36, 37
85535	33	250400	36
85530	34	250490	36
86258	29	250500	36
87417	28	250590	36

<u>Part No.</u>	<u>Page No.</u>
252725	27
270982	29
271605	29
271606	29
282288	20, 27
283167	25, 27
350241	38
350242	38
350244	18, 24, 38
350245	38
350282	38
350283	38
645006	28

A Complete Line of Lubrication Solutions and Industrial Pumping Products



Automated Lubrication

Our automated systems dispense measured amounts of lubricant at predetermined intervals. Systems include Helios® and Duo-Matic® two-line systems, Centro-Matic®, Modular Lube® and Quicklub® as well as ORSCO® precision oil lubrication. With our BearingSaver® program, we find the best automated solution for you from our wide range of systems for grease, fluid grease and oil.



General Lubrication

Lincoln has developed specialized pumps and pumping stations to handle the difficult job of transferring thick fluids. From the industry-best PileDriver III® and PowerMaster III® pumps and air motors to specialty pumps, controls and mounting accessories, Lincoln is the preferred pumping system for many tough applications.



Industrial Pumping

Sometimes a simple approach is the best solution. Our wide range of products includes smaller, self-contained automated lubricators and general lubrication equipment.

Lincoln's global distribution network is the best in the industry.

Whatever the service—evaluating your lubrication methods, installing a custom-engineered system, or supplying top-quality manual lubrication products—your Lincoln distributor makes certain you always get the very best value.

Systems House Distributors

Our systems house distributors offer the highest level of expertise available in the industry. They can custom design a system with the exact combination of Lincoln components you need. Then, they install the system in your plant with their knowledgeable technicians or work with your personnel to make sure the job is done correctly. Each distributor stocks a full inventory of pumps, metering devices, controllers, monitors and accessories. Each continues to meet our stringent requirements for product, systems and service knowledge. From Los Angeles to London, Boston to Bangkok, Lincoln's top-of-the-industry systems house distributors will be there when and where you need them.

For the nearest authorized Lincoln sales and service representative, call:

Americas:

St. Louis, Missouri
314-679-4200
Fax: 800-424-5359

Europe/Africa:

Walldorf, Germany
49-6227-33-0
Fax: 49-6227-33-259

Asia/Pacific:

Singapore
65-5627960
Fax: 65-5629967



Lincoln Industrial Corp.
One Lincoln Way
St. Louis, MO 63120-1578

Phone (314) 679-4200
Fax (314) 679-4359
www.lincolnindustrial.com

Form 442832 (3/2001)
© Copyright 2001
Printed in USA